

IX90 M440

Installation Guide

Verifone Part Number: DOC900-004-EN-A, Revision A01



www.verifone.com

IX90 M440 Installation Guide
© 2024 VeriFone, Inc.

All rights reserved. No part of this document may be reproduced or transmitted in any form without the written permission of VeriFone, Inc (“Verifone”).

The information contained in this document is subject to change without notice. Although Verifone has attempted to ensure the accuracy of the contents of this document, Verifone shall not be liable for technical or editorial errors or omissions contained herein. Verifone and the Verifone logo are registered trademarks of Verifone. Other brand names or trademarks associated with Verifone’s products and services are trademarks of Verifone.

All other brand names and trademarks appearing in this document are the property of their respective holders.

Comments? Please e-mail all comments on this document to your local Verifone Support Team.

Contents

Preface

Audience	5
Organization	5
Related Documentation	5
Conventions and Acronyms	6
Conventions	6
Acronyms	6

1. Device Overview

.....	9
-------	---

2. Specifications

IX90 - Connectivity and Power Supply	13
--	----

3. Accessories

Printer	14
Cash Drawer	14
Barcode Scanner	14

4. Device Setup

Safety Instructions	15
Periodic Inspection	15
Environmental Factors	16
Inside the Shipping Carton	16
Unpacking the Shipping Carton	16
To Scan the QR Code	18
Establishing Connections	18
Screen Angle Adjustment	20
IO Hub Connections	21
Connecting IX90 to a Power Source	22
To connect IX90 to a power source	23
Installing Printer	24
Installing Cash Drawer	24
Loading a Paper Roll in the Printer	25
To install a paper roll	26

IX90 Transactions 27
Alternative Payment Methods (APMs) 28

5. Service and Support

Maintenance and Cleaning 29
Service Returns 29
Accessories 30
 Connection Cables 31

6. Troubleshooting Guidelines

Device does not start/does not display correct readable information . . . 33
Blank display 34
Keypad does not respond 34
Transactions fail to process 34
 Checking Magnetic Card reader 34
 Checking Smart Card reader 34
 Checking CTLS reader 35

Preface

This guide is the primary source of information for setting up the IX90.

Audience

This guide is intended for the users involved in the installation of the IX90.

Organization

This guide is organized as follows:

- Chapter 1, [Device Overview](#). Provides an overview of the IX90.
- Chapter 2, [Specifications](#). Discusses power requirements, dimensions, and other specifications of the IX90.
- Chapter 3, [Accessories](#). Lists the various supported accessories that can be ordered.
- Chapter 4, [Device Setup](#). Explains the setup and installation, selecting a location, and establishing connections.
- Chapter 5, [Service and Support](#). Provides information on how to contact your local Verifone representative or service provider and information on how to order accessories or documentation from Verifone.
- Chapter 6, [Troubleshooting Guidelines](#). Provides troubleshooting guidelines.

Related Documentation



To learn more about the IX90, refer to the following documents associated with the Verifone Part Number (VPNs).

IX90 HUB Certifications and Regulations	VPN DOC900-002-EN
IX90 M440 QIG	VPN DOC900-005-EN
IX90 Printer and Cash Drawer QIG	VPN DOC900-006-EN
IX90 UX700 QIG	VPN DOC900-007-EN
IX90 Cable Management Base QIG	VPN DOC900-009-EN

Conventions and Acronyms

The following tables describe the conventions and acronyms.

Conventions

Convention	Meaning	Example
Blue	Text in blue indicates terms that are cross-referenced.	See Conventions and Acronyms
	The bulb icon is used to highlight important information.	If exchanging cables use a Verifone-approved cable.
	The caution symbol indicates possible hardware or software failure or loss of data.	Avoid placing metallic objects at the front of the card reader.
	The lightning symbol is used as a warning when bodily injury might occur.	For safety, do not string cables or cords across a walkway.

Acronyms

Acronym	Definition
AC	Alternating Current
AES	Advanced Encryption Standard
ARM	Advanced RISC Machine

Acronym	Definition
DC	Direct Current
EMV	Europay, MasterCard, and Visa
GMS	Google Mobility Services
LAN	Local Area Network
LCD	Liquid Crystal Display
MRA	Merchandise Return Authorization
MSR	Magnetic Stripe Reader
NFC	Near Field Communication
PCI	Payment Card Industry
PIN	Personal Identification Number
POS	Point-of-Sale
PTS	PIN Transaction Security
QR	Quick Response
RAM	Random Access Memory
ROM	Read Only Memory
SAM	Secure Access Module
SRED	Secure Reading and Exchange of Data

Acronym	Definition
TLS	Transport Layer Security
USB	Universal Serial Bus
VCPOS	Verifone Cloud Point of Sale

1. Device Overview

The Verifone IX90 is an Android-based POS system that offers a range of features to help merchants manage their business and provide a smooth payment experience to their customers. The system is equipped with an 11.6-inch multi-touch high-definition (HD) display that runs on the Android architecture, making it easy for merchants to interact with the system and conduct transactions. Additionally, the customer-facing terminal is designed to ensure fast and secure payments.

The IX90 solution is flexible and allows for the integration of other POS applications. The solution can be customized with accessories such as a cash drawer, printer, and a barcode scanner.

The dual-screen feature of the Verifone IX90 Countertop iPOS allows both the merchant and the customer to interact with a large, high-resolution HD display. This feature is particularly useful in situations where there is minimal counter space.

Verifone's estate management services enable clients to remotely monitor and update their payment devices. The Verifone payment device supports Bluetooth and Wi-Fi connectivity, as well as Ethernet and USB communications. It meets the PCI-PTS 5 requirements for maximum security.

The Verifone payment device supports all payment methods, including magnetic stripe, EMV, and NFC/contactless reader, along with popular mobile wallets like Apple Pay, Google Pay, and Samsung Pay. The device has an easy-to-read color touch screen that supports all payment-related user interactions and a keypad for secure PIN entry.

Figure: 1 IX90

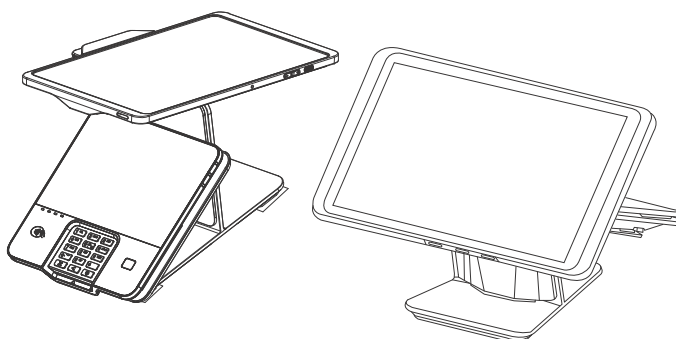

2. Specifications

This chapter lists the power requirements and other specifications of the IX90.

	Merchant Facing Display	Customer Facing Payment Display (M440)
OS	<ul style="list-style-type: none"> Android Go, version 12 	<ul style="list-style-type: none"> VAOS, Verifone Secure OS based on Android 8.1
Display	<ul style="list-style-type: none"> 11.6-inch FHD 1920 × 1080 multi-touch screen 	<ul style="list-style-type: none"> 8-inch 1280 × 720 HD resolution, multi-touch screen
Memory	<ul style="list-style-type: none"> 32GB Flash / 2GB RAM 	<ul style="list-style-type: none"> 16GB Flash / 2GB RAM / micro-SD memory expansion slot Secure Access Memory Slots x2
Processor	<ul style="list-style-type: none"> A133 64Bit Quad-core, 1.6GHz 	<ul style="list-style-type: none"> Quad-core Cortex-A7 1.1 GHz
Multimedia	<ul style="list-style-type: none"> Speaker Microphone Video Playback: 30 FPS full 720p HD 	<ul style="list-style-type: none"> Speaker and Audio Jack Microphone Video Playback: 30 FPS full 720p HD
Camera	<ul style="list-style-type: none"> Front: 2.0MP Rear: 5.0MP 	<ul style="list-style-type: none"> Front: 5 MP auto-focus
Card Readers	<ul style="list-style-type: none"> MSR Reader (only for Merchant Login) 	<ul style="list-style-type: none"> Triple Track MSR / Smart Card Reader / Contactless Card Reader
Certifications	<ul style="list-style-type: none"> GMS Certified 	<ul style="list-style-type: none"> EMV L1 & L2 / EMV Contactless L1, MasterCard Contactless / MasterCard TQM / VISA payWave / American ExpressPay / Discover D-PAS / Interac

	Merchant Facing Display	Customer Facing Payment Display (M440)
Environment	<ul style="list-style-type: none"> • Operating temperature: -10°C to 45°C • Storage temperature: -20°C to 70°C • Relative humidity: 90% non-Condensing 	<ul style="list-style-type: none"> • Operating temperature: -10°C to 45°C • Storage temperature: -20°C to 70°C • Relative humidity: 90% non-Condensing
Wireless Connectivity	<ul style="list-style-type: none"> • Wi-Fi 2.4GHz: 802.11 b/g/n • Wi-Fi 5GHz: 802.11 a/n/ac • Bluetooth: 5.0 BLE 	<ul style="list-style-type: none"> • Wi-Fi 2.4GHz: 802.11 b/g/n • Wi-Fi 5GHz: 802.11 a/n • Bluetooth: 4.2 BLE
Performance and Durability	<ul style="list-style-type: none"> • Durable Frame protection. • Supports Dual Band Wi-Fi for a reliable wireless connection. 	<ul style="list-style-type: none"> • Fast transactions due to powerful ARM Cortex processor. • This device is IP53 rated when mounted on the pedestal.
Ease of Use	<ul style="list-style-type: none"> • Supports Landscape and Portrait orientation. • Supports a +/-20 degree tilt. • Includes Magstripe reader for fast merchant login. 	<ul style="list-style-type: none"> • Touchscreen for icon-based applications or electronic signature capture support. • Intuitive telco-style keypad with colored control keys. • Bi-directional magnetic stripe card reader with an extended blade for optimal card reading. • Audio jack to facilitate accessibility for the visually impaired.

	Merchant Facing Display	Customer Facing Payment Display (M440)
Security	<ul style="list-style-type: none"> • Supports Android 12 privacy and security features inclusive of: <ul style="list-style-type: none"> • notification bar alerts • approximate location • privacy dashboard • private compute core 	<ul style="list-style-type: none"> • Supports a Verifone Proprietary operating system based on Android that is PCI/PTS compliant. • Incorporates tamper-sensing circuitry to detect unauthorized intrusion and supports a broad spectrum of software-based security features. • AES / RSA / TDES, PCI / PTS 5.1, SRED approved for debit and other PIN-based transactions. • Supports reliable security features including TLS, VeriShield file authentication, and VeriShield Protect to help prevent fraud and other intrusions.
Contactless Capability	<ul style="list-style-type: none"> • Not Applicable 	<ul style="list-style-type: none"> • Advanced contactless architecture with a single contactless interface (SingleCI). • Dedicated tap zone for optimized user experience. • Accepts EMV, NFC, QR Code and magstripe contactless payments as well as PIN-based transactions.

IX90 - Connectivity and Power Supply

IO HUB

- x1 Ethernet 100 Base-T
- x2 USB-A Host, 2.5W and 5W
- x1 USB-C Host

Power Supply

- 100-240V AC, 12V DC/3.3A/39W

3. Accessories

IX90 supports the following accessories which can be ordered separately:

Printer

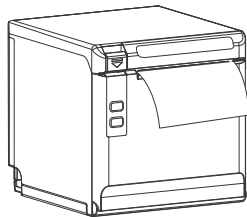

- Black : PRT000-NA-01-A, White : PRT000-NA-02-A
- TP808 Receipt Printer, Wi-Fi/USB, NA

Cash Drawer

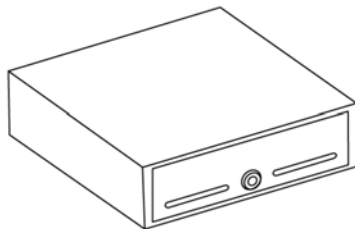

- Black : MSC000-032-01-A, White : MSC000-032-02-A
- MS CASH DRAWER STA-37965560 CD3-1313BK45-S2, 13WX13D, PRNTR DRVN, 4BILL-5COIN, 2 MEDIA SL
- The cash drawer has to be used alongside the Printer.

Barcode Scanner

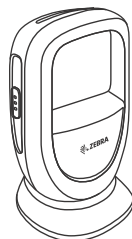

- Black : BCR414-209-02-A, White : BCR414-209-01-A
- Countertop 2D Barcode Scanner.

4. Device Setup

This chapter describes the setup procedure for the IX90 in the following sections:

- [Safety Instructions](#)
- [Periodic Inspection](#)
- [Environmental Factors](#)
- [Inside the Shipping Carton](#)
- [Establishing Connections](#)
- [Connecting IX90 to a Power Source](#)
- [Installing Printer](#)
- [Installing Cash Drawer](#)
- [Loading a Paper Roll in the Printer](#)
- [IX90 Transactions](#)
- [Alternative Payment Methods \(APMs\)](#)

Safety Instructions

- 1 Read all instructions before connecting the equipment. Do not attempt to install this device until all the instructions and warnings have been read and properly understood.
- 2 Make sure that there are no missing or defective parts - defective parts must never be used. Verifone is not liable or responsible for damage or injury caused by improper installation, improper use, or failure to observe these safety instructions. In such cases warranty might become void.
- 3 Do not use any attachments not specifically recommended by Verifone as they can result in the risk of fire, electric shock, or injury.
- 4 Do not use the device near water.
- 5 Do not place this unit on an unstable cart, stand, or table. The unit may fall, causing serious personal injury and/or damage to the equipment.

Periodic Inspection

- 1 It is recommended to periodically inspect the product and its fixing points to ensure that safety is maintained.
- 2 Periodically inspect the device for possible tampering. Signs of tampering include:

- Wires protruding out of the device.
- Foreign objects inserted into the smart card slot or magnetic stripe slot.
- Any bumps in the casing below the mag stripe slot and any noticeable additional mag stripe head from the side.
- Signs of damage to the tamper-evident labels.
- A Tamper Warning message on the device display.

If any device is found to have been tampered with, please remove it from the service immediately. Keep it available for potential forensics investigation and notify your company security officer and your local Verifone representative or service provider. To contact Verifone, please see [Service and Support](#).

For terminals equipped with a privacy shield, perform daily inspections to ensure that the privacy shield is installed and has not been removed.

Environmental Factors

- Do not use the device where there is excess heat, dust, humidity, moisture, caustic chemicals, or oils.
- Keep the device away from direct sunlight and anything that radiates heat.
- The contactless antenna is located around the display. Avoid having metallic objects in the proximity of a contactless antenna.
- Select a location convenient for the customer. Avoid dusty, hot, or damp locations.
- To minimize data reading or writing errors, pick a location free from magnetic interference. Choose a spot at a safe distance away from objects or units that generate magnetism.

Inside the Shipping Carton

Open the shipping carton and carefully inspect its contents for possible tampering or shipping damage.

Unpacking the Shipping Carton

To unpack the shipping carton:

- 1 Carefully inspect the shipping carton.
- 2 Validate the authenticity of the sender by verifying the shipping tracking number and other information located on the product order paperwork.
- 3 Remove the tape on the carton box.

- 4 Remove the inner carton box - once the tape is removed from the outer carton box, lift the inner carton box, and remove it from the outer carton box.
- 5 Unfold the inner carton box.
- 6 Inspect the contents of the shipping carton. The carton box contains the following as part of the IX90 product:

IX90-M440

- Merchant Facing Display
- Customer Facing Payment Display (M440)
- IO Hub
- Power supply for IO Hub
- Ethernet cable (2m)
- Privacy Shield
- Stylus
- Stylus holder for the M440
- Regional Power Supply

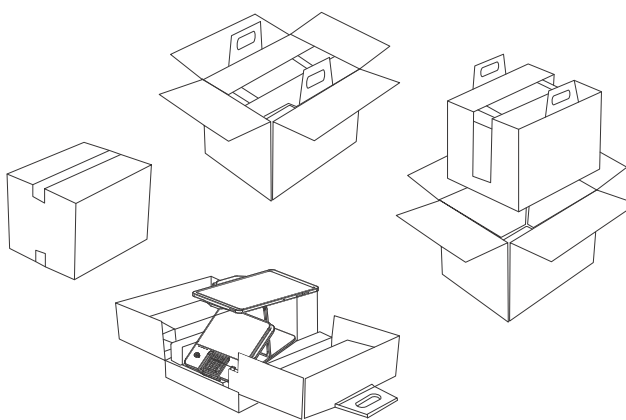

- Remove all the plastic wrapping from the device and the components.
- Remove the clear protective film from the customer-facing payment display and the branded protective film from the merchant facing display.

- Save the shipping carton and packing material for future repacking or moving of the device.



Do not use a tampered or damaged unit. The device comes equipped with tamper-evident labels. If a label or component appears damaged, please notify the shipping company and your Verifone service provider immediately.

N'utilisez pas un appareil trafiqué ou endommagé. L'appareil est équipé de étiquettes inviolables. Si une étiquette ou un composant semble endommagé, veuillez en informer immédiatement la compagnie maritime et votre fournisseur de services Verifone.

To Scan the QR Code Scan the QR code that is on the label of the carton box for User Manual and Support information. For more information on the related documents refer to [Related Documentation](#).



Establishing Connections

Following are the steps required to set up the IX90.

- Complete the IO hub connections, refer to the steps given in the [IO Hub Connections](#) section.
- Complete the paper roll installation, refer to the steps given in the [Loading a Paper Roll in the Printer](#) section.

- Complete the printer installation, refer to the steps given in the [Installing Printer](#) section.
- Complete the cash drawer installation, refer to the steps given in the [Installing Cash Drawer](#) section.
- Complete the IX90 power source connection, refer to the steps given in the [Connecting IX90 to a Power Source](#) section.

Figure: 2 IX90 Setup

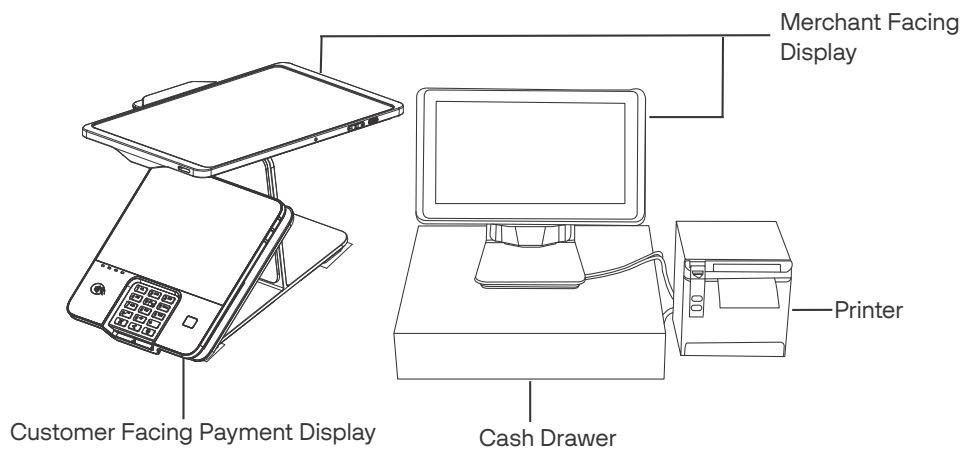

- Set the IX90 on a stable countertop.

- Set the preferred orientation. The merchant facing display can be used in both portrait and landscape mode. To change the orientation, pull on the pin located at the back and rotate it clockwise.

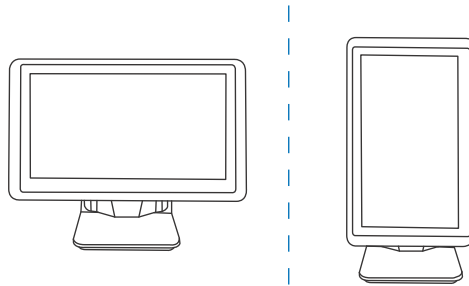
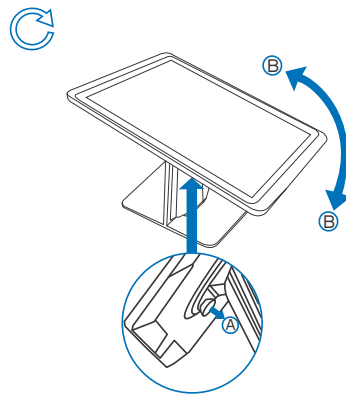

- Remove the branded screen protector film on the display.

Screen Angle Adjustment

By default, the screen angle is set to 45°. It can be tilted up to +/-20° to accommodate varying user and countertop heights.

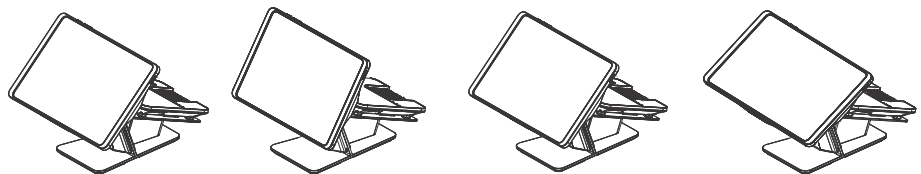

IO Hub Connections

Following are the steps to connect the cables that are coming out from the IO hub.

- 1 Connect PoUSB cable from the customer facing payment display to the payment port of the IO hub.
- 2 Connect USB-C cable from merchant facing display to the POS port of the IO hub.

Figure: 3 IO HUB

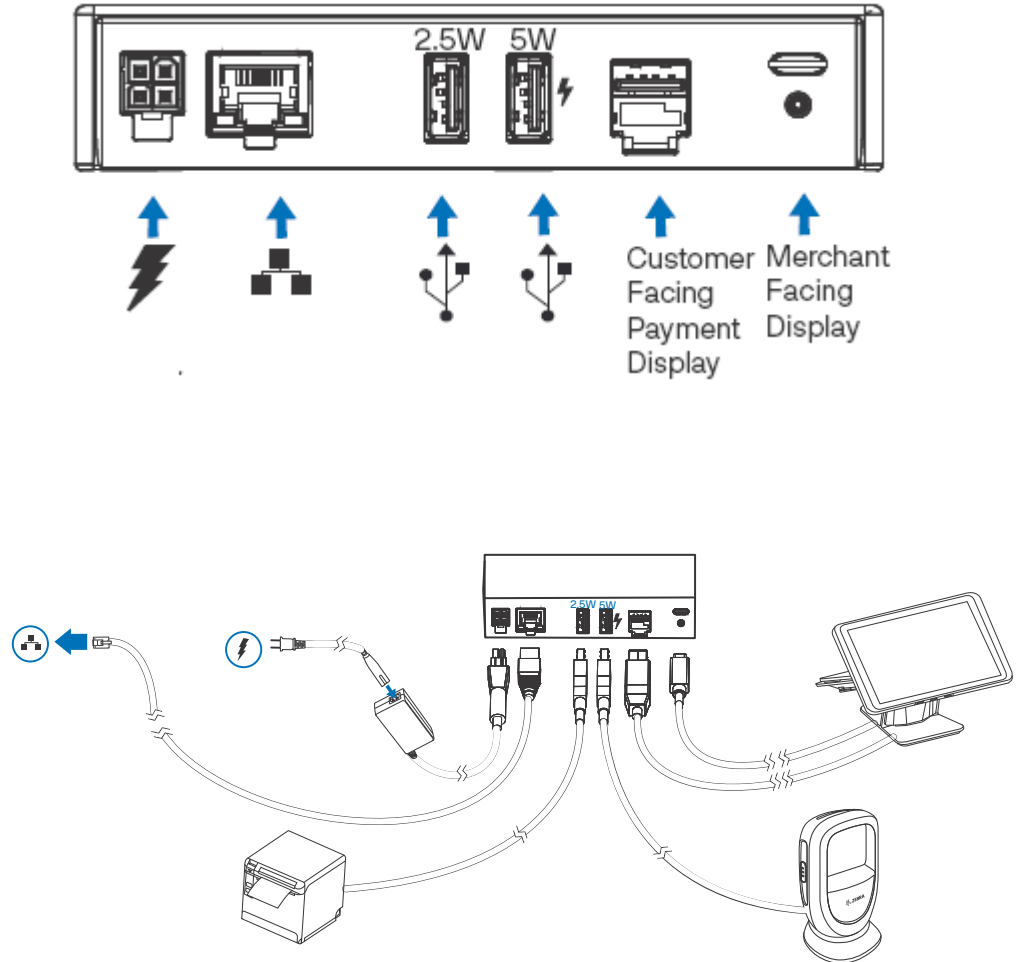

- 3 Connect USB-A (5W) cable from the Barcode reader to the USB port with the lightning bolt symbol on the IO hub and the USB-A (2.5W) cable from the Printer to another USB port on the IO hub respectively.
- 4 Connect the Cash Drawer cable to the Printer.
- 5 Connect one end of the LAN cable to the LAN port of the IO hub and another end to the ethernet wall socket.

- 6 Connect the power supply cable from the IO hub to the power source.

Connecting IX90 to a Power Source

The device is powered by an external AC/DC power pack. When you have finished installing the optional devices, you are ready to connect the device to the power source.

The device requires connection to a power outlet with a dedicated circuit or an uninterruptible power supply (UPS). If other devices are plugged into the same circuit, the device can potentially experience power fluctuations that might cause malfunction. The device shuts down automatically once the power source is removed.



CAUTION

- Do not connect the device to the power supply until all peripherals are attached.

Ne connectez pas l'appareil à l'alimentation électrique tant que tous les périphériques ne sont pas connectés.

- Using an incorrectly rated power supply can damage the unit or cause it not to work properly. Use only a power pack with P/N PWR445-001-1-A. See [Specifications](#) for detailed power supply specifications.

L'utilisation d'une alimentation mal calibrée peut endommager l'appareil ou l'empêcher de fonctionner correctement. Utilisez uniquement un bloc d'alimentation portant le numéro de pièce PWR445-001-1-A. Voir [Spécifications](#) pour les spécifications détaillées de l'alimentation.

- Disconnecting power during a transaction can also cause unsaved data files to be lost.

La déconnexion de l'alimentation pendant une transaction peut également entraîner la perte de fichiers de données non enregistrés.

- Verifone recommends installing a power surge protector to protect against possible damage caused by lightning strikes and electrical surges.

Verifone recommande d'installer un parasurtenseur pour se protéger contre d'éventuels dommages causés par la foudre et les surtensions électriques.

To connect IX90
to a power
source

- 1 Connect the power cable PWR159-002-01-B to the IO hub.

Figure: 4 Connecting
to a Power
Source

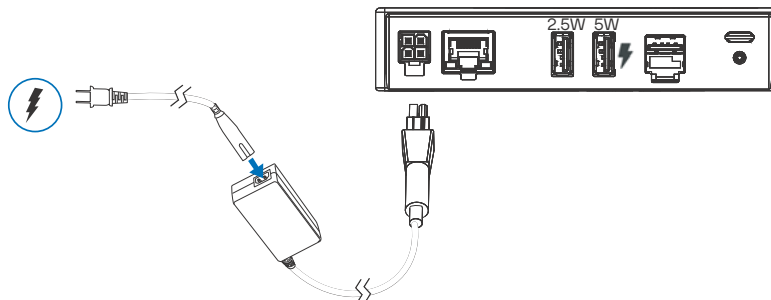

- 2 Plug the regional power cable into the power source (wall socket).



Your IX90 includes a battery and should always be connected to its power source for daily usage.

NOTE

Installing Printer

- 1 Printer ports are visible at the back of the printer as shown in [Figure 5](#).
- 2 Connect USB-B cable from the printer to the USB-A port of the IO hub.
- 3 Connect the power cord from the printer to the power source.

Figure: 5 Printer Connections

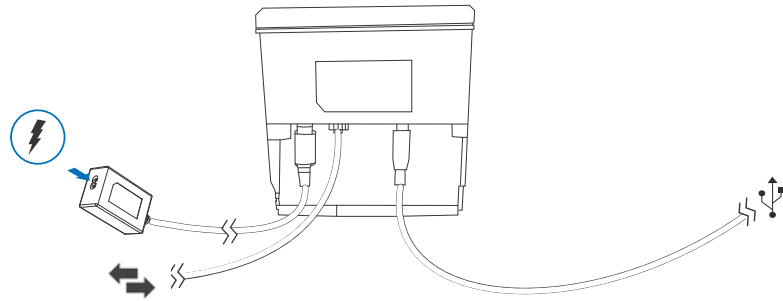

Installing Cash Drawer

- 1 Connection port of the cash drawer is at the back of the cash drawer.
- 2 Connect one end of the cable to the cash drawer and the other end to the Printer as shown in the below figure.

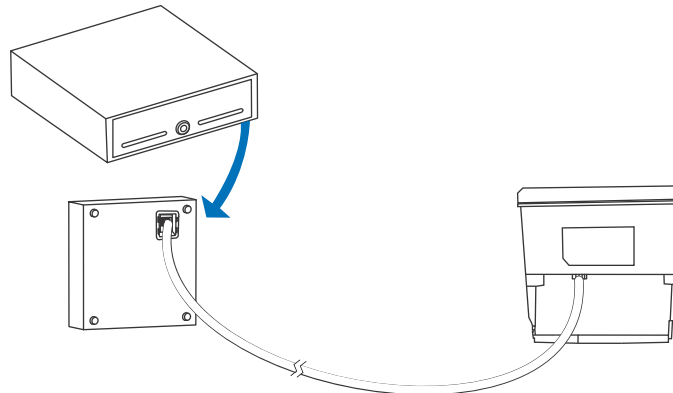

- 3 Cash Drawer and the printer are placed as shown in the below figure.

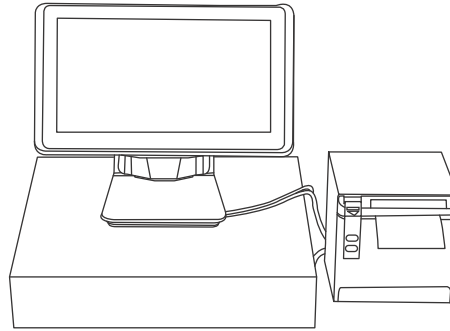

Loading a Paper Roll in the Printer

Install a paper roll before you can start the transaction that requires a receipt. The printer uses a roll of 40 mm, single-ply, thermal-sensitive paper.

A pink out-of-paper indicator line appears on the edge of the paper before the end of the roll. After this line appears there will be paper to perform only one more transaction.



CAUTION

- Poor-quality paper can jam the printer and create excessive paper dust. To place an order for high-quality Verifone paper roll, refer to [Accessories](#) section.

Un papier de mauvaise qualité peut bloquer l'imprimante et créer une poussière de papier excessive. Pour passer une commande d'un rouleau de papier Verifone de haute qualité, reportez-vous à la section Accessoires et documentation.

- Store thermal paper in a dry, dark area. Handle thermal paper carefully: impact, friction, temperature, humidity, and oils affect the color and storage characteristics of the paper.

Conservez le papier thermique dans un endroit sec et sombre. Manipulez le papier thermique avec précaution : les chocs, la friction, la température, l'humidité et les huiles affectent la couleur et les caractéristiques de stockage du papier.

- Never load a roll of paper with folds, wrinkles, tears, or holes at the edges.

Ne chargez jamais un rouleau de papier présentant des plis, des rides, des déchirures ou des trous sur les bords.

To install a paper roll

- 1 Open the paper door of the printer by pulling downwards.

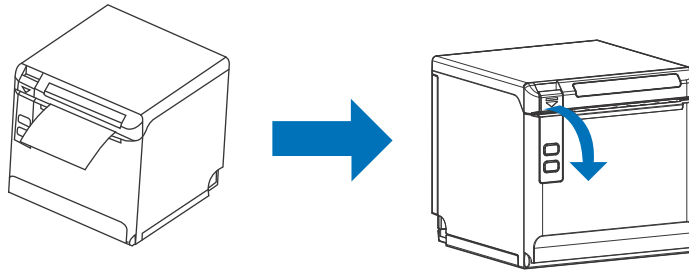

- 2 Remove any partial roll of paper in the tray.
- 3 Pull the paper past the printer door.
- 4 Loosen the glued leading edge of the new paper roll or remove the protective strip. Unwind the paper roll past any glue residue.
- 5 Hold the roll so that the paper feeds from the bottom of the roll.

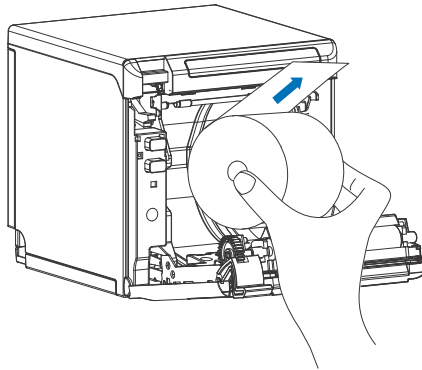
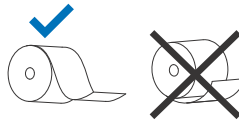

- 6 Align the printer paper to the tabs to the paper guides and hold the paper up when closing the door.

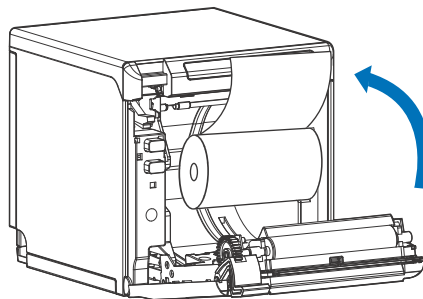

- 7 With the printer paper extending outside, close the printer door by swinging upward until the door clicks shut, allowing the printer paper to extend outside the printer door.

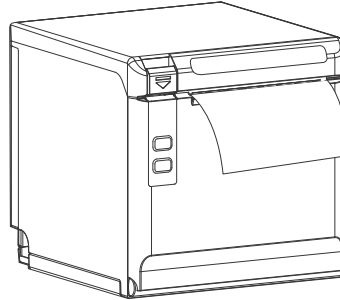

IX90 Transactions

Transaction Type

Insert

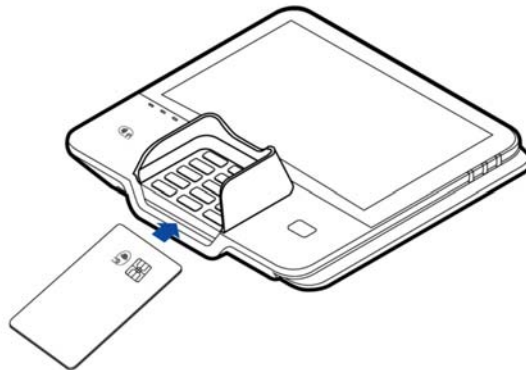

M440

Insert the smart card to proceed with the EMV transaction. EMV supports credit card and debit card transactions.

- Position the smart card with the contacts facing upward.
- Insert the card into the reader slot in a smooth, continuous motion until it sits firmly.
- Wait for the application to indicate a completed transaction before removing the card. Premature card removal invalidates the transaction.

Transaction Type

M440

Swipe

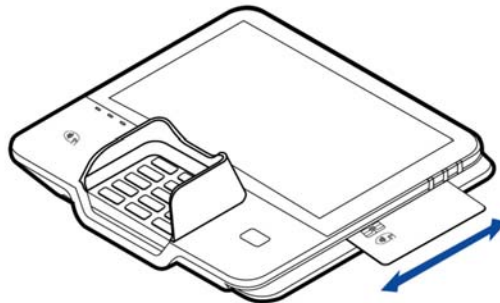

The device supports magnetic stripe cards as well as smart cards.

- Position the card with the magnetic stripe facing backward/downward.
- To ensure a proper read of the magnetic swipe card, insert the magnetic card from the side of the device.
- Swipe the card through the magnetic card reader.
- If using a card, insert the card and follow the on-screen instructions before removing the card.

CTLS

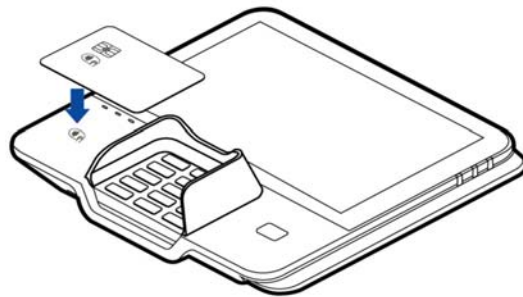

The device supports contactless credit or debit card transactions.

- Gently tap or hold the card on the surface of the display on the contactless logo.

Alternative Payment Methods (APMs)

Various payment methods are supported, allowing users to scan their mobile phones through the front camera of the terminal.

5. Service and Support

The IX90 has no user-serviceable parts. Unless otherwise instructed, do not, under any circumstance, attempt any service, adjustments, or repairs on the unit. Disconnect the unit before cleaning.

Maintenance and Cleaning

To clean the unit, periodically use a clean cloth, slightly dampened with water and a drop or two of mild soap. For stubborn stains, use alcohol or an alcohol-based cleaner.



CAUTION

Never use thinner, trichloroethylene, or ketone-based solvents - they can deteriorate plastic or rubber parts.

Because IX90 can be damaged by liquid, do not spray cleaners or other solutions directly onto the keypad or display. Always apply the cleaner to a cloth before cleaning the device.

N'utilisez jamais de solvants à base de diluant, de trichloréthylène ou de cétone - ils peuvent détériorer les pièces en plastique ou en caoutchouc.

Étant donné que le IX90 peut être endommagé par des liquides, ne vaporisez pas de nettoyants ou d'autres solutions directement sur le clavier ou l'écran. Appliquez toujours le nettoyant sur un chiffon avant de nettoyer l'appareil.

Service Returns

For IX90 equipment failures that cannot be resolved by your help desk or service department, contact one of the following hotlines for product service and repair information:

- USA - Verifone Service and Support Group, 1-800-Verifone (837-4366), Monday - Friday, 8 A.M. - 7 P.M., EST
- International - Contact your Verifone representative

Before returning IX90 to Verifone, you must obtain a Merchandise Return Authorization (MRA) number. The following procedure describes how to return one or more IX90 for repair or replacement (U.S. customers only).



NOTE

For international customers, please contact your local Verifone representative for assistance with your service, return, or replacement.

- 1 Get the following information from the printed labels at the back of each IX90 to be returned:
 - Product ID, including the model and part number. For example, “IX90” and “M900-XXX-XXX-XXX”
 - Serial number (S/N nnn-nnn-nnn)
- 2 Obtain the MRA number(s) by completing one of the following:
 - Call Verifone toll-free within the United States at 1-800-Verifone and follow the automated menu options.
 - Select the MRA option from the automated message. The MRA department is open Monday to Friday, 8 A.M.–8 P.M., Eastern Time.
 - Give the MRA representative the information you gathered in [Step 1](#).
 - Complete the Inquiry Contact Form at <https://www.verifone.com/en/us/contact-us>.
 - Address the Subject box to “Verifone MRA Dept.”
 - Reference the model and part number in the Note box.

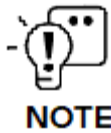

One MRA number must be issued for each IX90 you return to Verifone, even if you are returning several of the same models.

- 3 Describe the problem(s).
- 4 Provide the shipping address where the repaired or replacement unit must be returned.
- 5 Keep a record of the following items:
 - Assigned MRA number(s).
 - The Verifone serial number assigned to the IX90 you are returning for service or repair (device serial numbers are located at the back of the unit).
 - Shipping documentation, such as air bill numbers used to trace the shipment.
 - Model(s) returned (model numbers are located on the Verifone label at the back of the IX90).

Accessories Verifone produces the following accessories and documentation for the IX90. While ordering, please take note of the part number.

Contact information is as follows:

- <https://www.verifone.com/en/us/contact-us>.
- USA - Verifone Customer Development Center, 1- 800-Verifone (837-4366), Monday - Friday, 7 A.M. - 8 P.M., Eastern time
- International - Contact your Verifone representative.

Printer	<ul style="list-style-type: none"> • Black: PRT000-NA-01-A • White: PRT000-NA-02-A
Cash Drawer	<ul style="list-style-type: none"> • Black: MSC000-032-01-A • White: MSC000-032-02-A
Barcode Scanner	<ul style="list-style-type: none"> • Black: BCR414-209-02-A • White: BCR414-209-01-A

Connection Cables

IX90 M440	<ul style="list-style-type: none"> • CBL900-002-01-A 	<ul style="list-style-type: none"> • CABLE, IX90 M4XX TERMINAL TO IO HUB, 1M, 12V/1A
	<ul style="list-style-type: none"> • 27352-02-R 	<ul style="list-style-type: none"> • CABLE, ETHERNET BLK RJ45 TO RJ45 STRAIGHT 2M ROHS
Power supply	<ul style="list-style-type: none"> • PWR159-002-01-B 	<ul style="list-style-type: none"> • PS, 100-240VAC, 12VDC/ 3.3A/39W+CON, EFF L6, COC T2, LOT7
	<ul style="list-style-type: none"> • CBL000-080-01-A 	<ul style="list-style-type: none"> • POWER CORD, U.S.A, IEC320, C7, NEMA1-15P (UL) TYPE A, 125V/10A, 1.83M
	<ul style="list-style-type: none"> • CBL000-081-01-A 	<ul style="list-style-type: none"> • POWER CORD, EUROPE, IEC320, C7, CEE 7/16 II TYPE C, 250V/2.5A, 1.83M
	<ul style="list-style-type: none"> • CBL000-078-01-A 	<ul style="list-style-type: none"> • POWER CORD, U.K, IEC320, C7, BS1363 (BSI) TYPE G R/ A, 250V/5A, 1.83M 5.0 FUSE

SUB ASSY, IX90 IO HUB	<ul style="list-style-type: none">• SUB900-002-01-A	
Cable Management Base IX90	<ul style="list-style-type: none">• SUB900-004-01-A	

6. Troubleshooting Guidelines

The troubleshooting guidelines provided in the following section are to assist you in successfully installing and configuring your IX90. If you have problems operating your IX90, please read through these troubleshooting examples.

If the problem persists even after performing the outlined guidelines or if the problem is not described below, contact your local Verifone representative for assistance. Typical examples of malfunctions you may encounter while operating your IX90 and steps you can take to resolve them are listed.



NOTE

- The IX90 comes equipped with tamper-evident labels. The IX90 contains no user serviceable parts. Do not, under any circumstances, attempt to disassemble the unit. Perform only those adjustments or repairs specified in this guide. For all other services, contact your local Verifone service provider. Service conducted by parties other than authorized Verifone representatives may void any warranty.
- If the LAN connection to your IO Hub is removed during usage, then the merchant facing device will require a restart to switch the network to Wi-Fi and establish the connection.



CAUTION

Using an incorrectly rated power source can damage the unit or cause it to malfunction.

See [Specifications](#) for power source information.

L'utilisation d'une source d'alimentation mal évaluée peut endommager l'appareil ou provoquer un dysfonctionnement.

Voir Spécifications pour plus d'informations sur la source d'alimentation.

Device does not start/does not display correct readable information

If the device does not start:

- Ensure that the device is plugged into a dedicated power source.
- Check all the cable connections. Also, check if the power cable connector is plugged in properly.
- If the problem persists, contact your local Verifone representative for assistance.

Blank display

When the device display is blank:

- If the device display is dark, tap the screen with the stylus or your finger. If the unit was in screen-saver mode, the screen will turn on when touched.
- If the display does not show correct or readable information, check all cable connections. If the problem persists, contact your local Verifone representative for assistance.

Keypad does not respond

If the keypad does not respond properly:

- Check the device display. If it displays the wrong character or nothing at all when you press a key, follow the steps outlined in [Transactions Fail to Process](#).
- Refer to the user documentation for that application if pressing a function key does not perform the expected action to ensure you are entering data correctly.
- Contact your local Verifone representative if the problem persists.

Transactions fail to process

There are several possible reasons why the unit may not be processing transactions. Use the following steps to troubleshoot failures.

Checking Magnetic Card reader

To check the magnetic card reader:

- 1 Perform a transaction using one or more different magnetic stripe cards to ensure the problem is not a defective card.
- 2 Ensure that you are swiping cards properly.
- 3 Process a transaction manually using the keypad instead of the card reader. If the manual transaction works, the problem may be a defective card reader.
- 4 Contact your local Verifone representative if the problem persists.

Checking Smart Card reader

To check the smart card reader:

- 1 Perform a transaction using several different smart cards to ensure the problem is not a defective card.
- 2 Ensure that the card is inserted correctly.
- 3 Ensure the SAM cards are properly inserted in the slots and are properly secured.
- 4 Contact your local Verifone representative if the problem persists.

Checking CTLS reader To check the CTLS reader:
reader Ensure that there is no obstruction between the contactless logo and the card, that is in between the contactless reader and the actual card itself to perform a smooth transaction.

Verifone
2744N University Drive
Coral Springs,
FL 33065, USA



www.verifone.com



Thank you!

We are the payments architects who truly understand commerce.

As payment architects we shape ecosystems for online and in-person commerce experiences, including all the tools you need... from gateways and acquiring to fraud management, tokenization and reporting.

As commerce experts, we are here for you and your business. With our payment devices, our systems & solutions and our support. Everywhere. Anytime. So that your customers feel enabled, recognized and well taken care of, even beyond their expectations.

Verifone. Creating omni-commerce solutions that simply shape powerful customer experiences.