

**Verifone®**

V240m

*Installation Guide*



## V240m Installation Guide

© 2021 Verifone, Inc.

All rights reserved. No part of the contents of this document may be reproduced or transmitted in any form without the written permission of Verifone, Inc.

The information contained in this document is subject to change without notice. Although Verifone has attempted to ensure the accuracy of the contents of this document, this document may include errors or omissions. The examples and sample programs are for illustration only and may not be suited for your purpose. You should verify the applicability of any example or sample program before placing the software into productive use. This document, including without limitation the examples and software programs, is supplied "As-Is."

Verifone and the Verifone logo, are registered trademarks of Verifone. Other brand names or trademarks associated with Verifone's products and services are trademarks of Verifone, Inc.

All other brand names and trademarks appearing in this manual are the property of their respective holders.

### Product Warranty

For product warranty information, go to <http://www.verifone.com/terms>.

**Comments?** Please e-mail all comments on this document to your local Verifone Support Team.

Verifone Inc.  
1-800-Verifone  
[www.verifone.com](http://www.verifone.com)

Verifone Part Number: DOC474-003-EN-E, Revision E01



**CONTENTS**

**PREFACE** . . . . . 5

Audience . . . . . 5

Organization . . . . . 5

Related Documentation . . . . . 5

Guide Conventions . . . . . 5

    Acronym Definitions . . . . . 6

**CHAPTER 1**

**Overview**

        V240m Terminal . . . . . 7

            Front Functions . . . . . 7

            Back Functions . . . . . 8

            End Functions . . . . . 8

        V240m Bases . . . . . 9

            V240m Charging Base . . . . . 9

            V240m Full-Feature Base . . . . . 10

        Features and Benefits . . . . . 11

            Exceptional Ease of Use and Ergonomics . . . . . 11

            Critical Security Protection . . . . . 11

**CHAPTER 2**

**Setup**

        Selecting Location . . . . . 13

            Environmental Factors . . . . . 14

            Electrical Considerations . . . . . 14

            Contactless Considerations . . . . . 14

        PIN Protection Measures . . . . . 14

        Unpacking Shipping Carton . . . . . 15

        MSAM/uSD Cards . . . . . 15

            Opening Card Compartment . . . . . 15

            Changing or Installing MSAMs . . . . . 17

            Changing or Installing Micro SD Card . . . . . 17

            Changing or Installing SIM Card . . . . . 17

        Loading Printer Paper . . . . . 18

        Power Supply . . . . . 20

            USB Power Supply . . . . . 21

        Cable Connections . . . . . 21

            Cable Connections Using the Full-Feature Base . . . . . 22

        Smart Card Reader . . . . . 23

        Magnetic Stripe Card Reader Use . . . . . 24

        Contactless Transaction . . . . . 24

        Camera/Barcode Scanner . . . . . 25

        Optional Accessories . . . . . 25

            Full-Feature Base . . . . . 25

            Charging Base . . . . . 26

        Periodic Inspection . . . . . 26

<b>CHAPTER 3</b>		
<b>Specifications</b>	V240m Terminal . . . . .	27
	Unit Power Requirements . . . . .	27
	Temperature . . . . .	27
	Humidity . . . . .	27
	External Dimensions . . . . .	27
	Weight . . . . .	27
	Processor . . . . .	27
	Display . . . . .	27
	Magnetic Card Reader . . . . .	27
	Primary Smart Card . . . . .	27
	SAM Card Reader . . . . .	28
	Battery Pack . . . . .	28
	Security . . . . .	28
	V240m Bases . . . . .	28
	Unit Power Requirements . . . . .	28
	Temperature . . . . .	28
	Humidity . . . . .	28
	Security . . . . .	28
<b>CHAPTER 4</b>		
<b>Troubleshooting</b>	Display Panel Does Not Work . . . . .	29
<b>Guidelines</b>	Keypad Does Not Respond . . . . .	29
	Transactions Fail to Process . . . . .	29
<b>CHAPTER 5</b>		
<b>Verifone Service</b>	Maintenance and Cleaning . . . . .	31
<b>and Support</b>	Service Returns . . . . .	31
	Accessories and Documentation . . . . .	32
	Cables . . . . .	32
	Power Supply . . . . .	33
	Accessories . . . . .	33
	Documentation . . . . .	33
<b>APPENDIX A</b>	Caution and Warning Messages . . . . .	35



This guide is the primary source of information for setting up and installing V240m device.

**NOTE**



Verifone ships variants of the V240m terminal for different markets. Your terminal may have a different configuration, a different amount of memory, a different radio, and may or may not have a camera.

**Audience**

This guide provides simple descriptions of the V240m features and the basic information for installing and configuring the V240m.

**Organization**

This guide is organized as follows:

[Chapter 1, Overview](#). Provides an overview of a V240m device.

[Chapter 2, Setup](#). Explains how to set up and install the V240m and establish connections with other devices.

[Chapter 3, Specifications](#). Discusses the power requirements and dimensions of V240m.

[Chapter 4, Troubleshooting Guidelines](#). Provides troubleshooting tips.

[Chapter 5, Verifone Service and Support](#). Provides information on contacting your Verifone service provider, ordering accessories or documentation from Verifone, and maintaining the V240m unit.

[Appendix A, Caution and Warning Messages](#). Shows the UL/cUL certification-compliant translations of all Warning and Caution messages in this installation guide.

**Related Documentation**

To learn more about the V240m device, please refer to the following documents and their associated Verifone Part Numbers (VPN):

<i>V240m Certifications and Regulations</i>	VPN DOC474-001-EN
<i>V240m Quick Installation Guide</i>	VPN DOC474-002-EN

**Guide Conventions**



Please refer to the following document conventions for quickly identifying special formatting.

[Table 1](#) describes these conventions and provides examples of their use.

**Table 1 Document Conventions**

Convention	Meaning	Example
Blue	Text in blue indicates terms that are cross-references.	See <a href="#">Guide Conventions</a> .
<i>Italics</i>	Italic typeface indicates book titles or emphasis.	You <i>must</i> not use this unit underwater.

**Table 1 Document Conventions**

Convention	Meaning	Example
<p><b>NOTE</b></p> 	The pencil icon is used to highlight important information.	RS-232-type devices do not work on the communication port.
<p><b>CAUTION</b></p> 	The caution symbol indicates hardware or software failure, or loss of data.	The unit is not waterproof or dustproof and is intended for indoor use only.
<p><b>WARNING</b></p> 	The lightning symbol is used as a warning when bodily injury might occur.	Due to risk of shock do not use the unit near water.

**Acronym Definitions** Please refer to [Table 2](#) for the acronyms used in this manual.

**Table 2 Acronym Definitions**

Acronym	Definitions
3DES	Triple Data Encryption Algorithm
AC	Alternating Current
ANSI	American National Standards Institute
cUL	Underwriters' Laboratories of Canada
DC	Direct Current
DUKPT	Derived Unique Key Per Transaction Method as defined in the VISA's <i>POS Equipment Requirement: PIN processing and Data Authentication</i> , International Version 1.0, August 1988
ECR	Electronic Cash Register
EMV	Europay, MasterCard, and Visa
ISO	International Organization for Standardization
MRA	Merchandise Return Authorization
MSAM	Multiple Secure Access Module
LAN	Local Area Network
LCD	Liquid Crystal Display
LED	Light-Emitting Diode
PED	PIN Entry Device
PIN	Personal Identification Number
POS	Point-of-Sale
RS-232	Recommend Standard number 232
SAM	Secure Access Module
UL	Underwriters Laboratories
USB	Universal Serial Bus
VPN	Verifone Part Number



## Overview

This chapter presents the basics on the V240m terminal and base.

### V240m Terminal

The V240m is a consumer-facing handheld device. The product's design is equally appealing as a handheld PINpad and robust enough to look and function appropriately in a fixed mount setting.

The V240m can utilize over-the-air connectivity, facilitating mobile telephony technology for sending and receiving data, using existing operator-provided 2G, Wi-Fi, Bluetooth, or 3G connectivity.

This guide provides an introduction and basic setup procedures for V240m terminals.

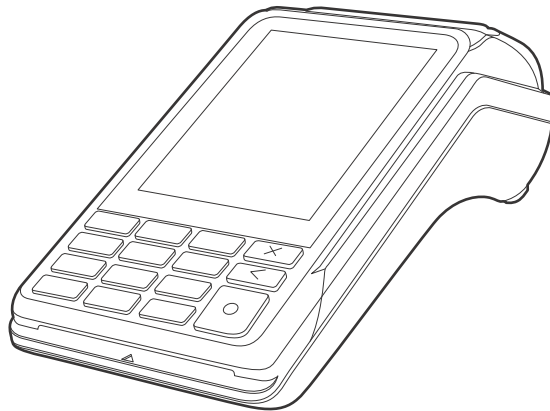

**Figure 1** V240m Front View

### Front Functions

The V240m includes the following features:

- Capacitive touch **LCD display** and **CTLS** tap area
- **Smart card** reader
- **Magnetic card** reader
- Integrated thermal **printer**
- Secure keypad supporting 3x5 matrix containing 0-9, \*, #, Cancel, Backspace/Clear, and Enter keys.
  - Dual-function Backspace/Clear key.
  - Customer-entry for Cancel and Enter keys.

**Back Functions** After removing the rear cover, the underside of the V240m device shows the following:

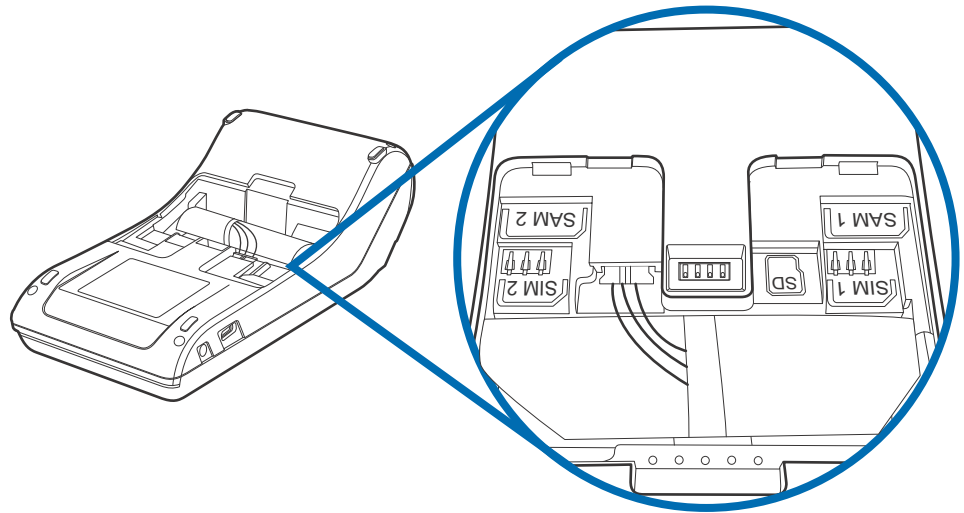

**Figure 2** V240m Underside Compartment View

- A **Micro SD** slot
- Dual **MSAM slots** to support stored-value card programs or other merchant card requirements
- Dual **SIM Card** compartments
- Battery

**End Functions** The V240m Camera variant includes an end-facing camera array that is capable of barcode and QR code scanning.:

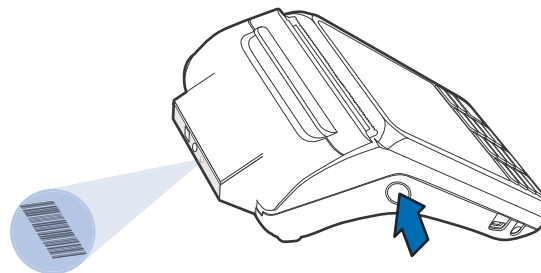

**Figure 3** V240m Camera Array



## V240m Bases

The V240m Base provides a stable mounted platform for the V240m terminal. The Base comes in two versions:

- V240m Charging Base
- V240m Full-Feature Base

The Charging Base supports charging only with no communication functionality. The Full-Feature Base supports several connectivity options and provides serial connection for peripherals (like ECR, check reader, barcode reader, etc.). The USB host port is for maintenance purposes and supports a USB flash drive.

### V240m Charging Base

The Charging Base accommodates and supplies power to the V240m and V240m Plus portable terminals.

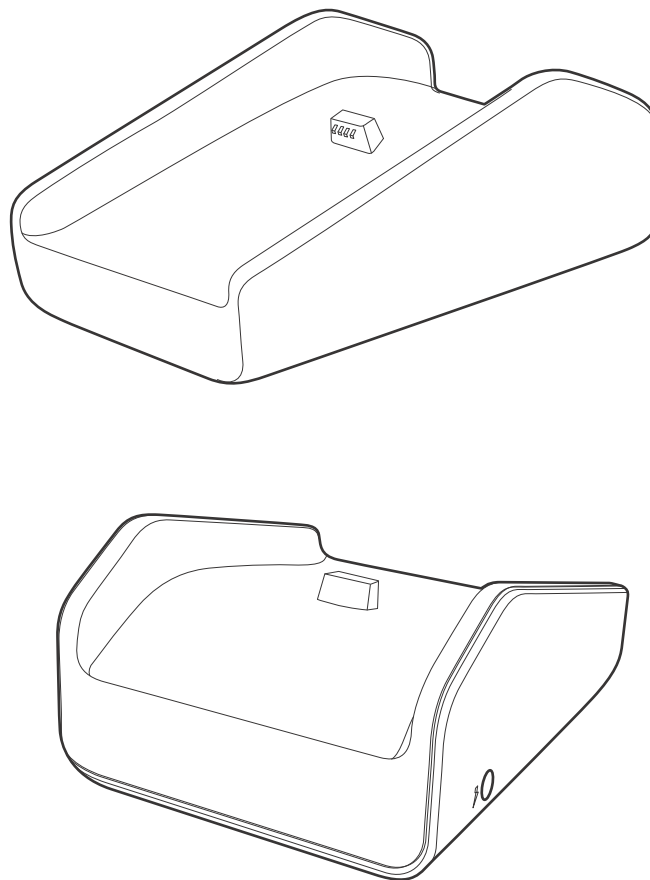
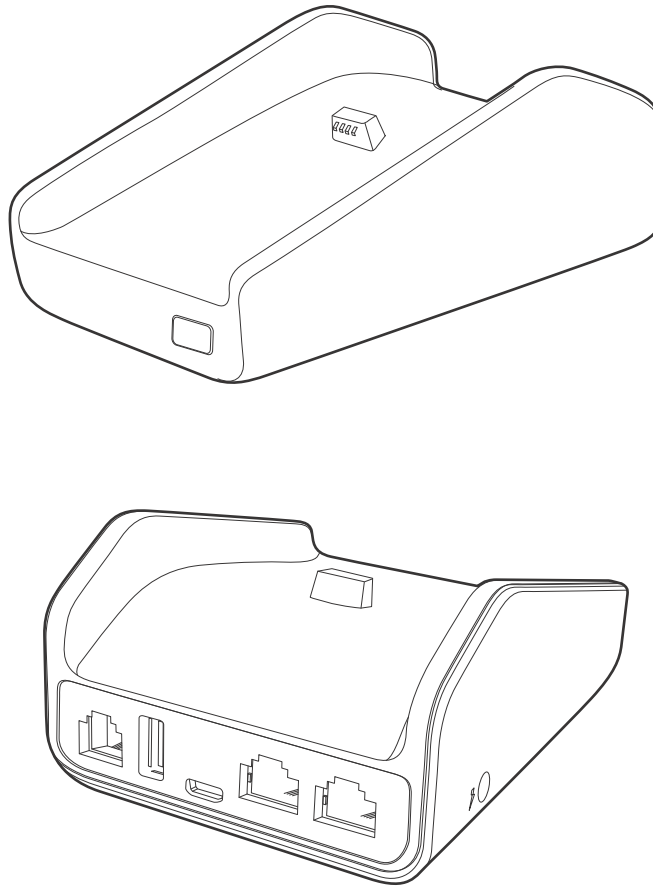

Figure 4 V240m Charging Base, Front and Rear

**V240m Full-Feature Base** The FF Base supports any failover communication via dial up and Ethernet connections for V240m. The failover will be supported in all network interfaces available in a terminal.



**Figure 5 V240m FF Base, Front and Rear**

The FF Base supports a maximum of seven simultaneous terminal connections via Bluetooth (BT) as well as the following:

Cable	Configuration
Ethernet port	RJ-45 socket (for connecting PINPad to LAN infrastructure)
RS232 port	RS232 socket (for connecting PINPad to LAN infrastructure), MOD-8 socket, Mini USB & DC-in jack
USB ports	Mini USB and type A USB

## Features and Benefits

The V240m terminal and V240m Bases provide the following functionality:

### Exceptional Ease of Use and Ergonomics

- Touch screen enables easy menu control and signature capture.
- Battery-powered for mobility and portable operation.
- Integrated thermal printer for fast transaction processing.
- Large, hard-rubber keys provide improved tactile feedback.
- 3.5" capacitive touch screen display.
- 2G capability (for V240m only).
- 3G functionality
- WiFi- and Bluetooth-capable.
- Intuitive keypad interface simplify training and reduce support requests.
- Using the Full-Feature Base, connects with most POS payment terminals, PCs, and ECRs.
- Supports payment transactions in a variety of payment environments.
- Rugged and reliable design absorbs hard knocks found at point-of-sale counters.
- Sleek and stylish shape occupies minimal counter space.
- Bold, ergonomic design fits comfortably in the palm of a hand.
- Optional Charging or Full-Feature Bases expand functionality while providing a stable, battery-charging platform.

### Critical Security Protection

- Offers a choice of Master/Session or DUKPT key-management methods to protect PIN-based transactions.
- Offers secure, reliable PIN input for expanding range of PIN-based transactions.
- PCI 5.x-compliant for secure solutions, meeting the PED standard.
- Meets ISO and ANSI standards for PIN encryption, key management, and MAC.
- Key injection simplified and secured with Verifone's SecureKit key loading software.

#### NOTE



Verifone ships variants of the V240m terminal for different markets. Your terminal may have a different configuration, a different amount of memory, a different radio, and may or may not have a camera.



## Setup

This chapter describes the setup procedure for the V240m and charging base, in the following sections:

- Selecting Location
- PIN Protection Measures
- Unpacking Shipping Carton
- MSAM/uSD Cards
- Power Supply
- Cable Connections
- Smart Card Reader
- Magnetic Stripe Card Reader Use
- Contactless Transaction
- Camera/Barcode Scanner
- Optional Accessories



Verifone ships variants of the V240m terminal for different markets. Your terminal may have a different configuration, a different amount of memory, a different radio, and may or may not have a camera.

### Selecting Location

Use the following guidelines to select the best location for the V240m device.

#### To Select a Location

Choose a location convenient for both merchant and client:

- Far from heavy metal objects,
- A flat support surface such as a countertop or a table,
- Near a power outlet and the terminal or computer that connects to the V240m.



For safety, do not string cables or cords across a walkway.

**Environmental Factors**

- Do not use the unit where there is high heat, dust, humidity, moisture, or caustic chemicals or oils.
- Keep the unit away from direct sunlight and anything that radiates heat, such as a stove or a motor.
- Do not use the V240m outdoors.



The V240m is not waterproof or dustproof and is intended for indoor use only. Any damage to the unit from exposure to rain or dust can void any warranty.

**Electrical Considerations**

- Avoid using this product during electrical storms.
- Do not use the V240m unit near water or in moist conditions.
- Disconnect the device from its POS terminal before cleaning.



Due to the risk of electric shock or damage to the terminal, do not use this equipment near a water source, for example near a bathtub, washbowl, kitchen sink or laundry tub, in a wet basement or near a swimming pool. Likewise, avoid using this product during thunderstorms causing power cuts. Avoid placing the terminal near electrical devices or other units that could cause large voltage fluctuations or electrical interference, such as air conditioners, neon signs, high frequency safety devices or electrical equipment.

**Contactless Considerations**

Avoid having metallic objects in proximity of the contactless antenna. If you need to mount the terminal to vertical or inclined surfaces, use a flat, non-metallic mounting plate.



Using an enclosed metal frame or mount may negatively affect contactless performance.

**PIN Protection Measures**

The V240m and V240m Plus are handover devices. Always exercise extreme caution when conducting transactions, especially during PIN entry:

- Hand the terminal directly to the cardholder for PIN entry.
- Encourage the cardholder to hold the terminal close to avoid others from seeing the information being entered.

Verifone also recommends instructing the cardholder regarding safe PIN-entry. This can be done with a combination of:

- Signage on the PED
- Prompts on the display with a click-through screen
- Literature at the point of sale
- A logo for safe PIN-entry process.

## Unpacking Shipping Carton

Carefully inspect the shipping carton and its contents for possible tampering or damage.

- 1 Remove the V240m unit from the shipping carton. The standard package contains the PIN pad, power pack, and printer paper roll. Refer to [Accessories and Documentation](#) for more information about V240m related accessories.



**Figure 6 V240m Box Contents**



This device is a secure product and any tampering can cause it to cease to function or operate in an unsecured manner.

- 2 Remove any protective plastic wrap and place the unit on a table or countertop.
- 3 Remove the clear protective film from the display.
- 4 Replace all the packing materials, close the lid, and save the carton for repacking or moving the V240m unit or base in the future.



Do not use a unit that has been tampered with or otherwise damaged. This unit comes equipped with tamper-evident label. If a label or component appears damaged, immediately notify the shipping company and your Verifone representative or service provider.

## MSAM/uSD Cards

You may need to install or replace the multiple security access module (MSAM), Micro Secure Digital (SD) and Subscriber Identity Module (SIM) cards.



Observe standard precautions in handling electrostatically sensitive devices. Electrostatic discharges can damage the equipment. Verifone recommends using a grounded anti-static wrist strap.

## Opening Card Compartment

Use the following steps to get access to the MSAM, SD and SIM card compartment:

- 1 Place the terminal face down on a soft and clean surface to protect the display from scratches.
- 2 Push down the locking tab and swing out the compartment cover.

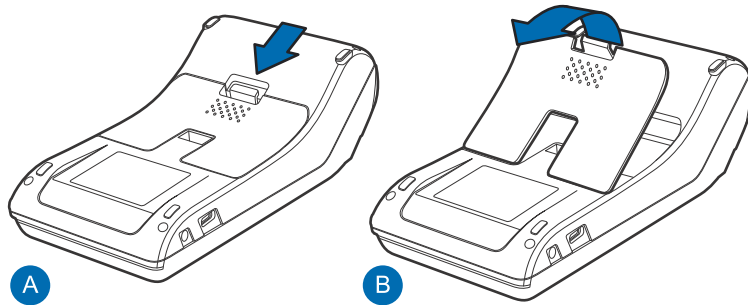

**Figure 7** Opening Rear Compartment

- 3 Do not remove the battery while accessing MSAM, SD and SIM.

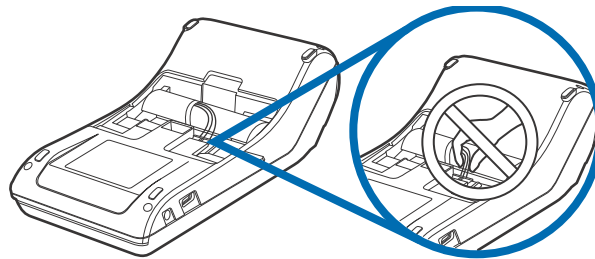

**Figure 8** Battery Removal



Ensure not to remove the battery. The battery should be removed only by the authorized service person.

- 4 Once you are done with inserting the card and replacing the battery, lock the rear cover back in place.



## Changing or Installing MSAMs

To change or install MSAM cards:

- 1 Use steps 1 to 3 of [Opening Card Compartment](#) to get to the MSAM cardholder.
- 2 Remove the old card, if any, and install the MSAM card by carefully sliding it into the slot (with the gold contacts facing downward) until fully inserted.

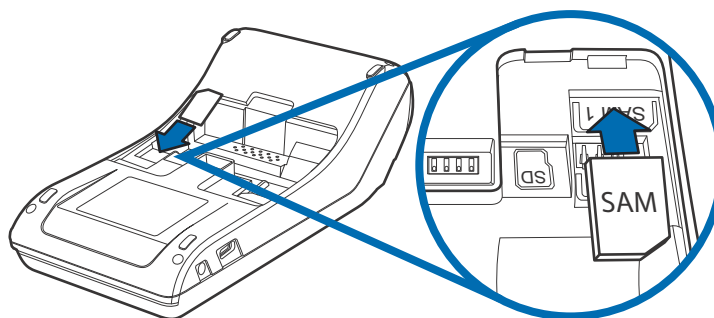

**Figure 9** Insert Micro MSAM

**NOTE**



Insert the card with the card's gold contacts facing away from you, toward the unit.

## Changing or Installing Micro SD Card

To change or install Micro SD cards:

- 1 Use steps 1 to 3 of [Opening Card Compartment](#) to get to the Micro SD cardholder.
- 2 Remove the old card, if any, and insert the Micro SD card by carefully sliding it into the slot (with the gold contacts facing downward) until fully inserted.

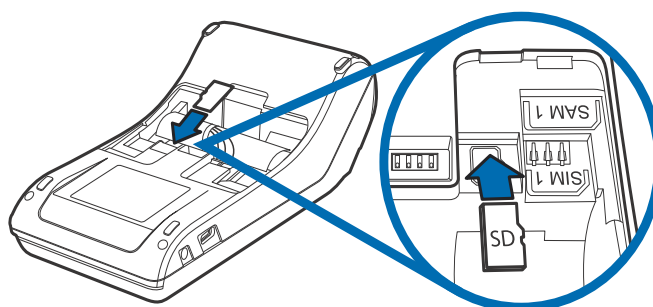

**Figure 10** Inserting Micro SD Card

**NOTE**



Insert the card with the card's gold contacts facing away from you, toward the unit.

## Changing or Installing SIM Card

To change or install SIM cards:

- 1 Use steps 1 to 3 of [Opening Card Compartment](#) to get to the SIM cardholder.

- 2 Remove Micro SIM Adaptor as step A and insert Micro SIM (If it is not Nano SIM) as Step B.

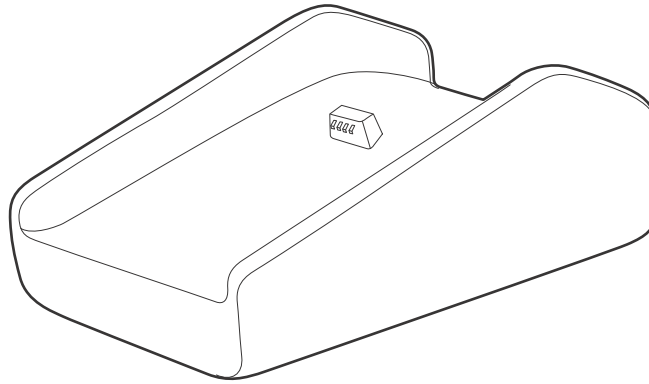

**Figure 11 Removing the Micro SIM Adaptor and insert Micro SIM**

**NOTE**



Insert the card with the card's gold contacts facing away from you, toward the unit.

- 3 Insert Nano SIM in Micro SIM Adaptor and install the Micro SIM Adaptor by carefully sliding it into the slot (with the gold contacts facing downward) until fully inserted.

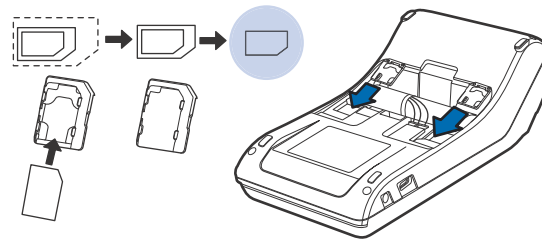
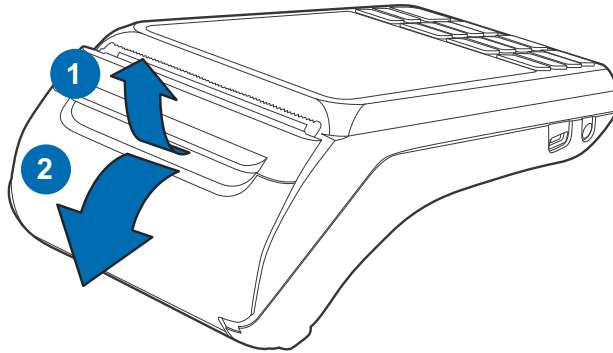

**Figure 12 Inserting the Nano SIM in Micro SIM Adaptor**

## Loading Printer Paper

Use the following steps to load a roll of 57 mm x 40 mm thermal printer paper into the compartment.

- 1 Unlock the paper compartment by pulling up the latch and swinging the door downwards.



**Figure 13** Opening Printer Paper Door

- 2 Load the paper roll as shown in Figure 14, with the edge of the paper on the top of the roll.

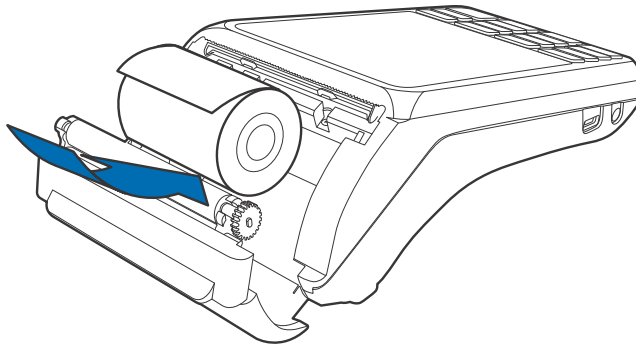

**Figure 14** Loading Paper Roll

- 3 Pull a length of paper up over the serrated cutter and close the compartment door.

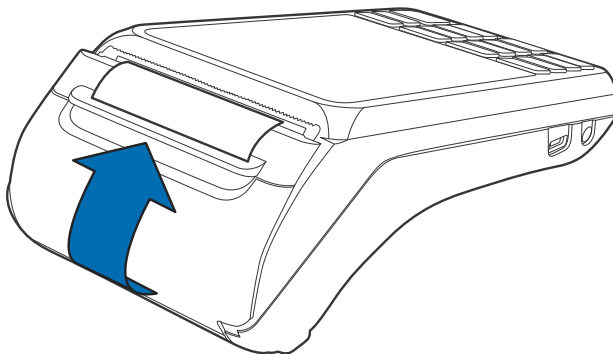

**Figure 15** Closing Printer Door



**CAUTION** Before processing transactions in battery mode, make sure you have more than 10% battery life. Do not risk losing transaction data or printing capabilities, connect the terminal to the power pack if battery level is below 10%.

## Power Supply

Not all configurations and device contexts require the use of a power supply – Verifone ships power supply with the terminal as required.

Contact your Verifone representative if you have changed the context in which the terminal is used or have questions about which power supply should be used.



Using an incorrectly rated power supply can damage the unit or cause it not to work properly. Use only a power pack with VPN PWR474-002-01-A (see [Verifone Service and Support](#) for detailed power supply specifications).

Disconnect the power pack cord from the power outlet before connecting a power supply. Connect and route all cables between the terminal, ECR, and PC before plugging the power pack cord into a wall outlet or surge protector.

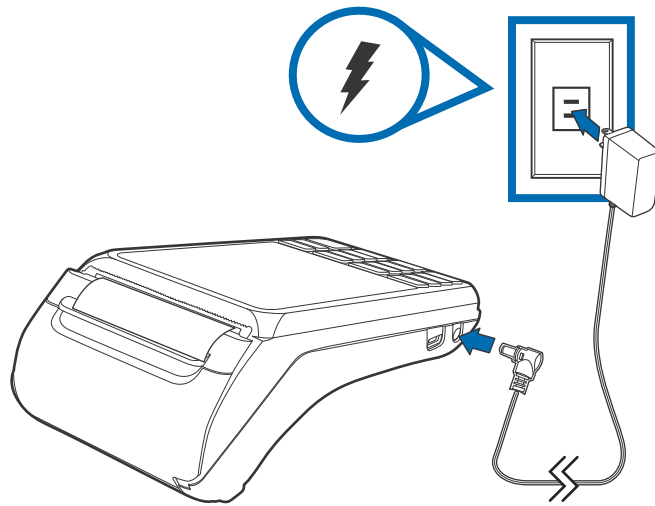

**Figure 16** Connecting the Power Pack



Do not plug the power pack into an outdoor outlet or operate the terminal outdoors. Disconnecting power during a transaction can cause transaction data files not yet stored in memory to be lost.



Verifone recommends installing a power surge protector to protect against possible damage caused by lightning strikes and electrical surges.

When the terminal has power and an application is loaded, the application starts after the initial Verifone copyright screen and displays a unique copyright screen. If no application is loaded, **DOWNLOAD NEEDED** appears on the display after the initial Verifone copyright screen.

**USB Power Supply** The V240m can be powered with 5V supply from USB port (5V at 1A) with the following power-saving conditions controlled by the OS:

- Micro-processor operating frequency is set to 300 MHz in CTLS mode.
- Switch off multi-media playback function when CTLS payment mode is activated.
- Reduce audio output volume.
- LCD backlight intensity is reduced to 30% (not suitable for high-glare, outdoor usage).
- Keypad backlight is disabled.
- BT and Wi-Fi functions are unavailable.
- Maximum audio output volume is reduced.
- Ethernet functionality is unavailable.
- Multi-media function (video playback or audio function) must be switched off by user or customer app when CTLS payment mode is activated. Other modes of payment like smart card and MSR payment can be supported.

**NOTE**



CTLS payment mode is defined as the state of the device where RF transmission is broadcasting to allow for a CTLS payment. This is activated either during the scanning of items or at the completion of scanning items during the checkout process, depending on how the application sets it up. As soon as checkout is complete, the device exits CTLS payment mode and remains off until activated for the next checkout.

**Cable Connections**

You can connect the V240m to peripherals using the Full-Function Base.

- [Cable Connections Using the Full-Feature Base](#)

**WARNING**



Turn off or unplug the terminal when connecting or disconnecting the device to avoid device memory corruption and data loss.

Refer to the controlling device instructions for any terminal-specific warnings.

**Cable Connections Using the Full-Feature Base**

To connect the terminal to other devices via Ethernet, RS-232, and USB, use the V240m Full-Feature (FF) Base. The FF Base provides a standard RJ-45 LAN socket, RS-232 port, a mini-USB port. The V240m terminal must be docked on the base to utilize cable connectivity

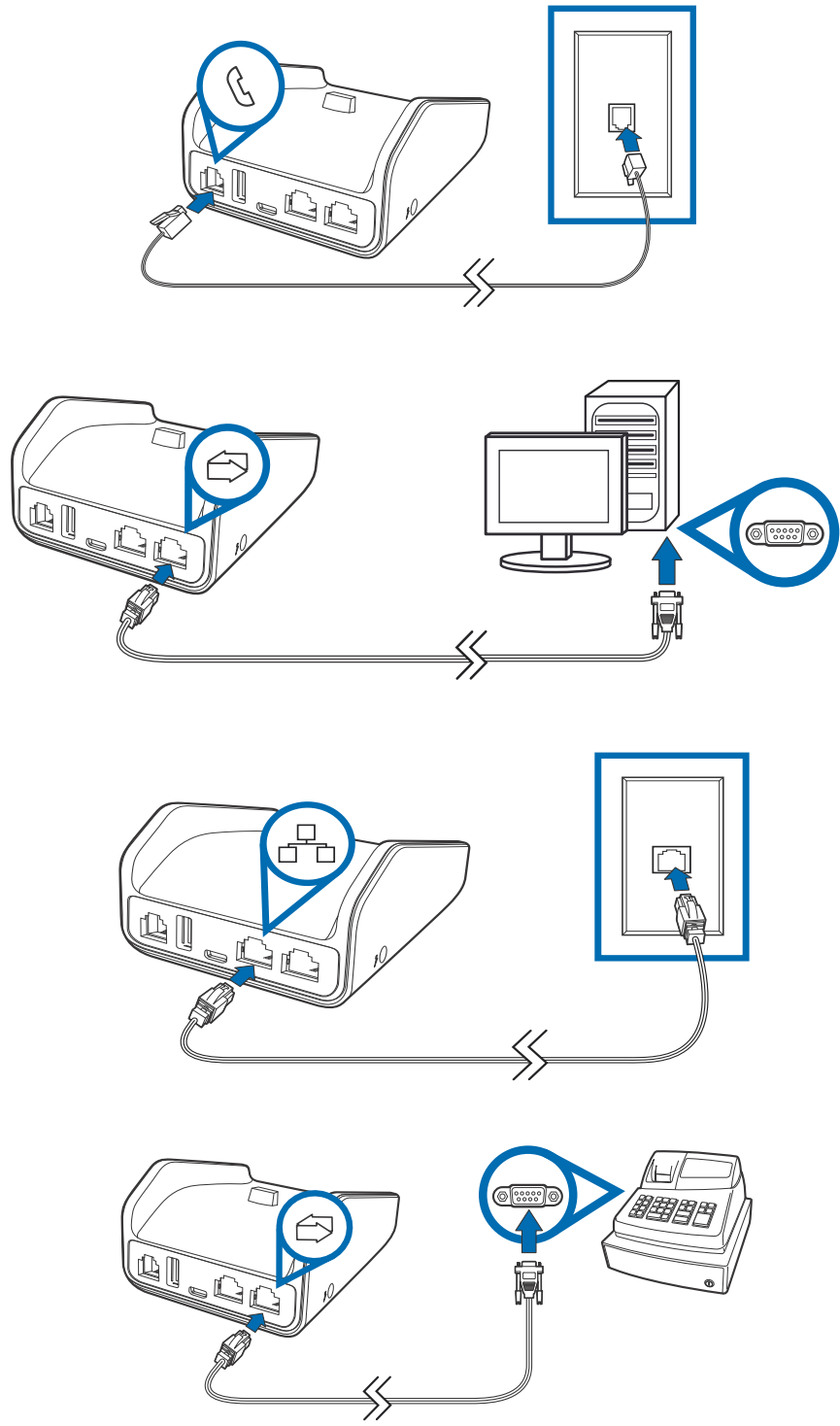

**Figure 17 Full-Feature Base Peripheral Connections**

The Full-Feature Base features the following:

Cable	Configuration
Ethernet port	RJ-45 socket (for connecting PINPad to LAN infrastructure)
RS232 port	RS232 socket (for connecting PINPad to LAN infrastructure), MOD-8 socket, Mini USB & DC-in jack
USB ports	Mini USB and type A USB

## Smart Card Reader

The smart card transaction procedure can vary depending on the application. Verify the proper procedure with your application provider before performing a smart card transaction.

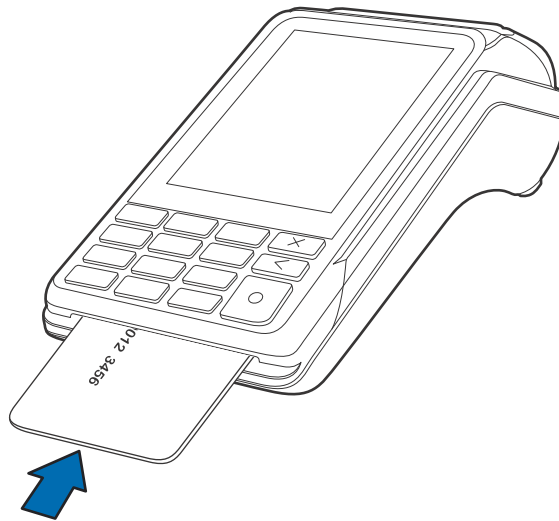

**Figure 18 Using the Smart Card Reader**

### Conducting a Smart Card Transaction

To conduct a smart card transaction:

- 1 Position the smart card with the gold contacts facing upward.
- 2 Insert the card into the smart card reader slot in a smooth, continuous motion until it seats firmly.
- 3 Remove the card when the display indicates the transaction is completed.



**CAUTION** Leave the smart card in the card reader until the transaction is completed. Premature removal can void the transaction.

## Magnetic Stripe Card Reader Use

The V240m has a magnetic card reader that uses a triple track stripe reader. This gives the unit greater reliability over a wide range of swipe speeds and operating environments.

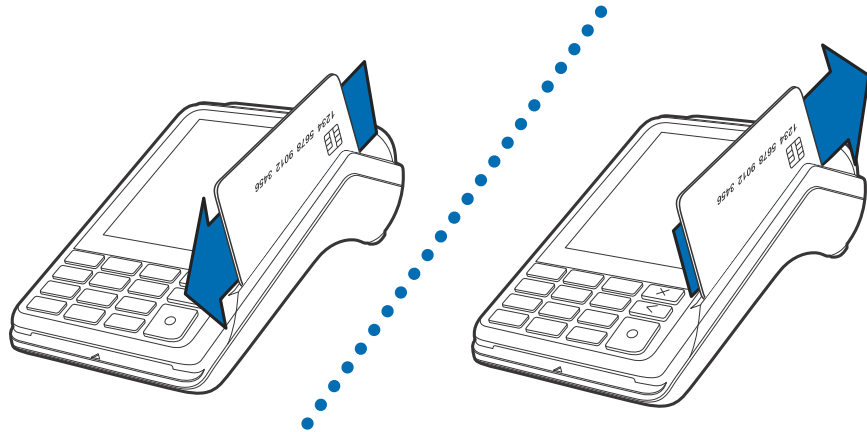

**Figure 19** Using the Magnetic Stripe Card Reader

### Conducting a Credit/Debit Card Transaction

To conduct a credit or debit card transaction:

- 1 Position a magnetic card with the stripe facing the keypad.
- 2 Swipe it through the magnetic card reader.

## Contactless Transaction

The V240m supports contactless transactions through an integrated contactless module. The terminal only becomes active for contactless smart card transactions when initialized by an application.

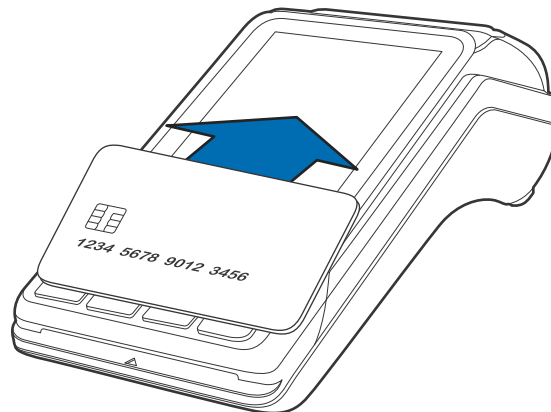

**Figure 20** Contactless Transaction

### Performing Contactless Transactions

To perform a contactless smart card transaction:

- 1 Gently tap the card onto or hold the card (within 4 cm) against the surface of the display where the contactless logo appears.
- 2 An activated LED visual on the display accompanied by a short beeping sound indicates a successful transaction.

See [Contactless Considerations](#) for more information.



## Camera/Barcode Scanner

The V240m Camera variant includes an end-facing camera array that is capable of barcode and QR code scanning.

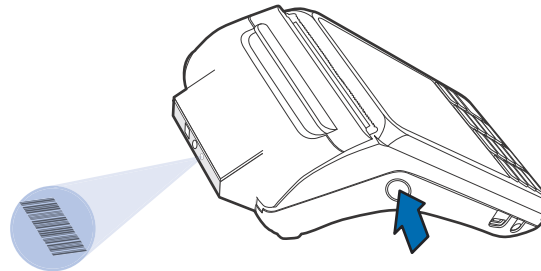

**Figure 21** V240m Camera array

## Optional Accessories

These accessories can be used to further enhance the device's functionality. See [Accessories and Documentation](#) for additional information.

### Full-Feature Base

The Full-Feature Base (VPN M474-S02-08) provides Bluetooth (BT) v4.2 as well as All BT v4.1 features. It also supplies power, Dial up, Ethernet, USB Host and USB Device, plus powered RS232 connection. See [Cable Connections Using the Full-Feature Base](#).

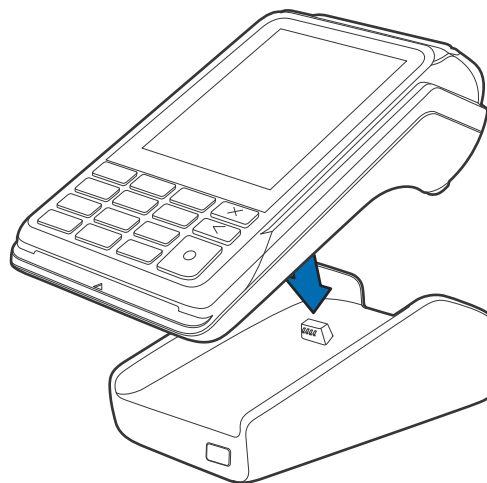

**Figure 22** V240m Docking with Full-Feature Base

**Charging Base** The Charging Base (VPN M474-S02-00) provides a stable dock plus power charging for the V240m terminal.

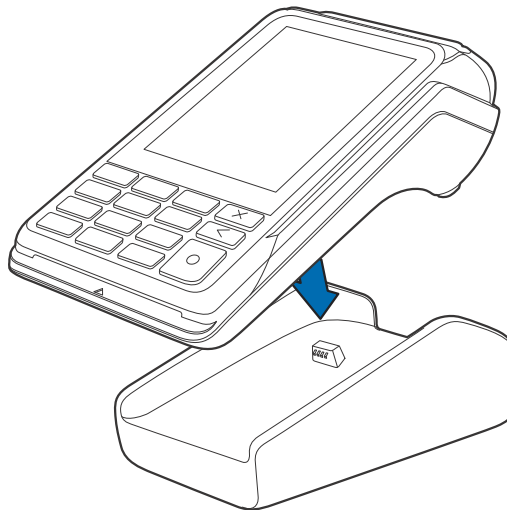

**Figure 23** V240m Docking with Charging Base

## Periodic Inspection

Periodically inspect the terminal for possible tampering. Signs of tampering may include:

- Wires protruding from the device.
- Foreign objects inserted into the smart card or mag stripe slot.
- Signs of damage to the tamper-evident label.
- Warning message on the device display.

---

**NOTE**

If any device is found in tamper state, please remove it immediately from service. Keep it available for potential forensic investigation and notify your company security officer and your local Verifone representative or service provider. For more information on contacting Verifone, refer to [Verifone Service and Support](#).

---



## Specifications

This chapter discusses power requirements, dimensions, and other specifications of the V240m terminal and bases.

### V240m Terminal

Refer to the following specifications for the V240m terminal:

#### Unit Power Requirements

V240m devices have the following power requirements:

- |                    |                           |                                       |
|--------------------|---------------------------|---------------------------------------|
| • Operating power: | <b>V240m</b><br>5V DC, 1A | <b>V240m Camera</b><br>5V DC, 1A/2.2A |
|--------------------|---------------------------|---------------------------------------|

#### Temperature

- Operating temperature: 0°C to 50°C (32° to 122°F)
- Storage temperature: -20°C to 60°C (-4° to 140°F)

#### Humidity

- Relative humidity: 5% to 90% (RH non-condensing)

#### External Dimensions

- |           | <b>V240m</b>      | <b>V240m Camera</b> |
|-----------|-------------------|---------------------|
| • Length: | 162.9 mm (6.4 in) | 172.4 mm (6.8 in)   |
| • Width:  | 75.3 mm (2.9 in)  | 75.3 mm (2.9 in)    |
| • Depth:  | 53.4 mm (2.1 in)  | 53.4 mm (2.1 in)    |

#### Weight

- |                |                                  |   |
|----------------|----------------------------------|---|
| • Unit weight: | <b>V240m</b><br>320 g (11.28 oz) | <b>V240m Camera</b><br>330 g (11.64 oz) |
|----------------|----------------------------------|---|

#### Processor

- ARM Cortex A9 32-bit processor

#### Display

- 3.5" portrait mode transmissive TFT 320 (RGB) x 480 (HVGA)

#### Magnetic Card Reader

- Triple track (tracks 1, 2, 3), high coercivity, bi-directional

#### Primary Smart Card

- ISO 7816-3, 1.8V, 3V, 5V
- Synchronous and Asynchronous cards
- EMV Approved

**SAM Card Reader**

- Two Security Access Modules (SAMs)

**Battery Pack**

- Rating: 9.1 Wh (3.7V DC, 2450 mAh)
- Meets IEEE1725 requirements

**Security**

- 3DES encryption, Master/Session and DUKPT key management
- VeriShield file authentication
- PCI PED 5.x approved

**V240m Bases****Charging Base**

- Provides terminal charging on a mounted stand

**Full-Feature Base**

- Aside from charging, the FF Base provides:
  - Bluetooth
  - 10/100M Ethernet
  - 56K modem
  - Powered RS-232
  - LE Secure feature of BT v4.2 + All BT v4.1 feature
  - USB host
  - USB device

**Unit Power Requirements**

- Operating power: 5V DC, 2.2A (FF Base)  
5V DC 1A (Charging Base)

**Temperature**

- Operating temperature: -5°C to 50°C (23° to 122°F)
- Storage temperature: -20°C to 60°C (-4° to 140°F)

**Humidity**

- Relative humidity: 5% to 95% (RH non-condensing)

**Security**

- PCI 5.x Compliant.



## Troubleshooting Guidelines

This chapter lists typical malfunctions that may occur while operating a V240m device and the appropriate corrective action. If the problem persists – even after performing the outlined guidelines, or if the problem is not described, contact your local Verifone representative for assistance.

**NOTE**

The V240m device uses a tamper-evident case and contains no user-serviceable parts. Do not, under any circumstance, attempt to disassemble the unit. Perform only those adjustments or repairs specified in this guide. For all other services, contact your local Verifone service provider. Service conducted by parties other than authorized Verifone representatives may void any warranty.

### Display Panel Does Not Work

Use the following steps to check the display panel:

- 1 Check all the cable connections.
- 2 Check the controlling device's AC outlet to be sure the outlet is supplying sufficient power. Substitute the controlling device's power pack with another power pack.
- 3 The controlling device's application program might not be loaded correctly. Download the application program and try again.
- 4 If the problem persists, contact your local Verifone representative.

### Keypad Does Not Respond

Use the following steps to check the keypad:

- 1 Check the display panel. If there are no characters, or the wrong characters are displayed, refer to [Display Panel Does Not Work](#).
- 2 If the problem persists, contact your local Verifone representative.

### Transactions Fail to Process

There are several possible reasons why the unit may not be processing transactions. Use the following steps to troubleshoot failures.

#### **Check Magnetic Card Reader**

- Perform a test transaction using one or more different magnetic stripe cards to ensure the problem is not a defective card.
- Ensure that you are swiping cards properly (see [Magnetic Stripe Card Reader Use](#)).
- Process a transaction manually using the keypad instead of the card reader. If the manual transaction works, the problem may be a defective card reader.

- If the problem persists, contact your local Verifone representative.

### **Check Smart Card Reader**

- Perform a test transaction using several different smart cards to ensure the problem is not a defective card.
- Ensure that the card is inserted correctly (see [Magnetic Stripe Card Reader Use](#)).
- Ensure the MSAM cards are properly inserted in the slots and are properly secured (see [MSAM/uSD Cards](#)).
- If the problem persists, contact your local Verifone representative.



## Verifone Service and Support

### Maintenance and Cleaning

The V240m device has no user-serviceable parts. Unless otherwise instructed, do not, under any circumstances attempt any service, adjustments, or repairs on the unit. Disconnect the device before cleaning.

To clean the unit, periodically use a clean cloth, slightly dampened with water and a drop or two of mild soap. For stubborn stains, use alcohol or an alcohol-based cleaner. For best results, use a Verifone Cleaning Kit (refer to [Accessories and Documentation](#)).



Never use thinner, trichloroethylene, or ketone-based solvents – they can deteriorate plastic or rubber parts.

Because the V240m can be damaged by liquid, do not spray cleaners or other solutions directly onto the keypad or display. Always apply the cleaner to a cloth before cleaning the device.

Contact your local Verifone representative or service provider for any problems on your device.

- For product service and repair information:
- USA – Verifone Service and Support Group, 1-800-837-4366,
- Monday - Friday, 8 A.M. - 8 P.M., Eastern time
- International – Contact your Verifone representative

### Service Returns

You must obtain a Merchandise Return Authorization (MRA) number before returning the device to Verifone. The following procedure describes how to return one or more devices for repair or replacement (U.S. customers only).



Customers outside the United States are advised to contact their local Verifone representative for assistance regarding service, return, or replacement of devices and accessories.

#### *Returning One or More Devices for Repair or Replacement*

- 1 Gather the following information from the printed labels on the bottom of each device to be returned:
  - Product ID, including the model and part number. For example, “V240m”, “M474-xxx-xx”.
  - Serial number (S/N xxx-xxx-xxx).
- 2 Obtain the MRA numbers by completing the following:

- Call Verifone within the United States toll-free at 1-800-Verifone and follow the automated menu options.
- Select the MRA option from the automated message. The MRA department is open Monday–Friday, 8 A.M.–8 P.M., Eastern time.
- Give the MRA representative the information gathered in [Step 1](#).
- Complete the Inquiry Contact Form at <https://www.verifone.com/en/us/contact-us>.
- Address the Subject box to “Verifone MRA Dept.”
- Reference the model and part number in the Note box.



One MRA number must be issued for each device you return to Verifone, even if you are returning several of the same model.

- 3 Describe the problem(s).
- 4 Provide the shipping address where the repaired or replacement unit must be returned.
- 5 Keep a record of the following items:
  - Assigned MRA number(s).
  - Verifone serial number assigned to the device you are returning for service or repair (serial numbers are located on the bottom of the unit).
  - Shipping documentation, such as air bill numbers used to trace the shipment.

Model(s) returned (model numbers are located on the Verifone label on the bottom of the device).

### Accessories and Documentation

Verifone produces the following accessories and documentation for the V240m. When ordering, please take note of the part number.

- Verifone online store [www.estore.verifone.com](http://www.estore.verifone.com)
- USA – Verifone Customer Development Center, 800-Verifone (837-4366), Monday - Friday, 7 A.M. - 8 P.M., Eastern time
- International – Contact your Verifone representative

### Cables

Contact your local Verifone distributor to determine which cable fits your needs.

CBL280-025-02-A	USB Cable 4.1 m
CBL282-045-XX-A	USB cable (as Device). Powered from +9V/1A DC adaptor
CBL282-038-XX-A	USB cable (as Device). Powered from +5V USB Host.
CBL282-033-01-A	Powered USB cable (as Device). Powered from +12V PUSB Host



CBL282-031-XX-A	RS-232 cable (DB9). Powered from +12V DC adaptor.
CBL282-036-XX-A	RS-232 cable (RJ45). Powered from Countertop (+12 V).
CBL282-006-01-B	Cable, VX 820 Ethernet/RS232, Dongle 1.0 m

### Power Supply

PWR474-002-XX-A	DC power pack (V240m)
PWR475-010-XX-A	DC power pack (V240m Camera)

### Accessories

02746-01	Verifone Cleaning Kit
----------	-----------------------

### Documentation

DOC474-001-EN	V240m Certifications and Regulations
DOC474-002-EN	V240m Quick Installation Guide





## Caution and Warning Messages

Products with UL/cUL certification should include French translations of Caution and Warning notices. The following table lists all notices found in the document, their location, and the equivalent French translations.

**Table 3 Caution and Warning Messages**

Notice	Chapter	Page	English Text	French Text
Warning	Setup	page 13	For safety, do not string cables or cords across a walkway.	<i>Par mesure de sécurité, ne pas les câbles de chaîne ou de cordons à travers une passerelle.</i>
Caution	Setup	page 14	This unit is not waterproof or dustproof and is intended for indoor use only. Any damage to the unit from exposure to rain or dust can void any warranty.	<i>Cet appareil n'est pas étanche ou à la poussière, et est destiné à une utilisation en intérieur. Tout dommage à l'unité de l'exposition à la pluie ou à la poussière peut annuler la garantie.</i>
Caution	Setup	page 14	Using an enclosed metal frame or mount may negatively affect contactless performance.	<i>L'utilisation d'un cadre métallique fermé ou de montage peut affecter négativement contact performance.</i>
Warning	Setup	page 14	Due to the risk of electric shock or damage to the terminal, do not use this equipment near a water source, for example near a bathtub, washbowl, kitchen sink or laundry tub, in a wet basement or near a swimming pool. Likewise, avoid using this product during thunderstorms causing power cuts. Avoid placing the terminal near electrical devices or other units that could cause large voltage fluctuations or electrical interference, such as air conditioners, neon signs, high frequency safety devices or electrical equipment.	<i>Du fait d'un risque d'électrocution ou d'une détérioration du terminal, ne pas utiliser cet équipement près d'une source d'eau, par exemple près d'une baignoire, d'un lavabo, d'un évier de cuisine ou d'un bac de lavage, dans un sous-sol humide ou à proximité d'une piscine. De même, éviter d'utiliser ce produit lors des orages provoquant des coupures électriques. Éviter de placer le terminal à proximité d'appareils électriques ou autres unités pouvant entraîner des fluctuations de tension importantes ou des interférences électriques, tels que les climatiseurs, enseignes au néon, dispositifs de sécurité à haute fréquence ou équipements électriques.</i>
Caution	Setup	page 15	This device is a secure product and any tampering can cause it to cease to function or operate in an unsecured manner.	<i>Cet appareil est un produit sûr et toute manipulation peut l'amener à cesser de fonctionner ou fonctionner de manière non sécurisée.</i>

**Table 3** Caution and Warning Messages (continued)

Notice	Chapter	Page	English Text	French Text
Warning	Setup	page 15	Do not use a unit that has been tampered with or otherwise damaged. This unit comes equipped with tamper-evident label. If a label or component appears damaged, immediately notify the shipping company and your Verifone representative or service provider.	<i>Ne pas utiliser un appareil qui a été altéré ou endommagé. Cet appareil est équipé d'étiquette d'inviolabilité. Si une étiquette ou d'un composant semble être endommagé, en aviser immédiatement la compagnie maritime et votre représentant Verifone ou prestataire de services.</i>
Caution	Setup	page 15	Observe standard precautions in handling electrostatically sensitive devices. Electrostatic discharges can damage the equipment. Verifone recommends using a grounded anti-static wrist strap.	<i>Respecter les précautions standard dans la manipulation d'appareils sensibles aux décharges électrostatiques. Les décharges électrostatiques peuvent endommager le matériel. Verifone recommande d'utiliser un bracelet anti-statique à la terre.</i>
Caution	Setup	page 20	Using an incorrectly rated power supply can damage the unit or cause it not to work properly. Use only a power pack with VPN PWR474-002-01-A.	<i>L'utilisation d'une alimentation incorrecte peut endommager l'appareil ou ne pas fonctionner correctement. Utilisez uniquement un bloc d'alimentation avec VPN PWR474-002-01-A.</i>
Caution	Setup	page 20	Do not plug the power pack into an outdoor outlet or operate the terminal outdoors. Disconnecting power during a transaction can cause transaction data files not yet stored in memory to be lost.	<i>Ne branchez pas le bloc d'alimentation dans une prise extérieure ou n'utilisez pas le terminal à l'extérieur. La déconnexion de l'alimentation pendant une transaction peut entraîner la perte des fichiers de données de transaction qui ne sont pas encore stockés dans la mémoire.</i>
Warning	Setup	page 21	Turn off or unplug the terminal when connecting or disconnecting the device to avoid device memory corruption and data loss. Refer to the controlling device instructions for any terminal-specific warnings.	<i>Éteignez ou débranchez le terminal pour connecter ou déconnecter le dispositif pour éviter la corruption de la mémoire de l'appareil et la perte de données. Reportez-vous aux instructions de l'appareil de contrôle pour tous les avertissements spécifiques au terminal.</i>

**Table 3** Caution and Warning Messages (continued)

Notice	Chapter	Page	English Text	French Text
Caution	Setup	page 23	Leave the smart card in the card reader until the transaction is completed. Premature removal can void the transaction.	<i>Laissez la carte à puce dans le lecteur de carte jusqu'à ce que la transaction soit terminée. Le retrait prématuré peut annuler la transaction.</i>
Caution	Service and Support	page 31	Never use thinner, trichloroethylene, or ketone-based solvents – they can deteriorate plastic or rubber parts. Because this device can be damaged by liquid, do not spray cleaners or other solutions directly onto the keypad or display. Always apply the cleaner to a cloth before cleaning the device.	<i>N'utilisez jamais de diluant, le trichloréthylène ou des solvants cétoniques - ils peuvent détériorer les pièces en plastique ou en caoutchouc. Parce que cet appareil peut être endommagé par un liquide, ne pas vaporiser de nettoyage ou d'autres solutions directement sur le clavier ou l'écran. Toujours appliquer le nettoyant sur un chiffon avant de nettoyer l'appareil.</i>





Verifone, Inc.  
1-800-Verifone  
[www.verifone.com](http://www.verifone.com)

# V240m

## *Installation Guide*

